



Intrinsically Safe MLTX2 Transmitter

Radio Remote Control Technical Manual



MAGNETEK

March 2022
Part Number: 198-80202-2001 R05
© 2022 Magnetek

SERVICE INFORMATION

For questions regarding service or technical information contact:

1.866.MAG.SERV (1.866.624.7378)

International Service

Outside the U.S. and Canada call +1.262.783.3500, press 3.

Columbus McKinnon Corporation Locations

Magnetek

N49 W13650 Campbell Drive
Menomonee Falls, WI 53051

Telephone: 800.288.8178

E-mail: field.service@magnetek.com

Fax Numbers:

Main: 800.298.3503

Sales: 262.783.3510

Service: 262.783.3508

Canada

161 Orenda Road
Unit 1
Brampton, Ontario
L6W 1W3 Canada

Telephone: 800.792.7253

Fax: 905.828.5707

416.424.7617 (24/7 Service pager)

Germany

STAHL CraneSystems GmbH

Telephone: +49 7940 128-0

E-mail: mh.eurosales@magnetek.com

Website

<https://www.columbusmckinnon.com/magnetek>

© 2022 Columbus McKinnon Corporation

All rights reserved. This notice applies to all copyrighted materials included with this product, including, but not limited to, this manual and software embodied within the product. This manual is intended for the sole use of the person(s) to whom it was provided, and any unauthorized distribution of the manual or dispersal of its contents is strictly forbidden. This manual may not be reproduced in whole or in part by any means whatsoever without the expressed written permission of the Columbus McKinnon Corporation.

PRODUCT SAFETY INFORMATION

INTRODUCTION

Thank you for your purchase of Magnetek's XLTX Radio Remote Control.

These instructions are to be used as a reference for personnel operating the XLTX Radio Remote Control and the equipment that this XLTX Radio Remote Control is attached to.

The user of these instructions should have basic knowledge in the handling of electronic equipment.

Magnetek® offers a broad range of radio remote control products, control products and adjustable frequency drives, and industrial braking systems for material handling applications. This manual has been prepared by Magnetek to provide information and recommendations for the installation, use, operation and service of Magnetek's material handling products and systems (Magnetek Products). Anyone who uses, operates, maintains, services, installs or owns Magnetek Products should know, understand and follow the instructions and safety recommendations in this manual for Magnetek products.

The recommendations in this manual do not take precedence over any of the following requirements relating to machine safety:

- Instructions, manuals, and safety warnings of the manufacturers of the equipment where the radio system is used,
- Plant safety rules and procedures of the employers and the owners of facilities where the Magnetek Products are being used,
- Regulations issued by the Occupational Health and Safety Administration (OSHA), Conformité Européenne (CE), etc.
- Applicable local, state or federal codes, ordinances, standards and requirements, or
- Safety standards and practices for the overhead material handling industry.

This manual does not include or address the specific instructions and safety warnings of these manufacturers or any of the other requirements listed above. It is the responsibility of the owners, users and operators of the Magnetek Products to know, understand and follow all of these requirements. It is the responsibility of the owner of the Magnetek Products to make its employees aware of all of the above listed requirements and to make certain that all operators are properly trained. **No one should use Magnetek Products prior to becoming familiar with and being trained in these requirements.**

WARRANTY INFORMATION

FOR INFORMATION ON MAGNETEK'S PRODUCT WARRANTIES BY PRODUCT TYPE, PLEASE VISIT WWW.COLUMBUSMCKINNON.COM/MAGNETEK.

TABLE OF CONTENTS

SERVICE INFORMATION	2
PRODUCT SAFETY INFORMATION	3
INTRODUCTION	3
1 WARNINGS AND CAUTIONS	6
2 CRITICAL INSTALLATION CONSIDERATIONS	7
2.1 GENERAL	7
2.2 PERSONS AUTHORIZED TO OPERATE RADIO CONTROLLED EQUIPMENT	7
2.3 SAFETY INFORMATION AND RECOMMENDED TRAINING FOR RADIO CONTROLLED EQUIPMENT OPERATORS	8
2.4 TRANSMITTER UNIT	9
2.5 PRE-OPERATION TEST	9
2.6 HANDLING BATTERIES	9
2.7 BATTERY DISPOSAL	10
2.8 CRANE/LIFTING DEVICE SPECIFIC WARNINGS	10
2.9 SPECIFIC CONDITIONS OF SAFE USE	11
3 MLTX2 TRANSMITTER STANDARD CONFIGURATION AND OPERATION	12
3.1 INSTALLING BATTERY PACK	13
3.1.1 Approved Batteries for Intrinsically Safe Operation	13
3.1.2 Intrinsically Safe Alkaline Battery Pack	13
3.2 TURNING THE TRANSMITTER ON AND OFF	15
3.2.1 Turning On the Transmitter (with Standard Status LED Indicator(s))	15
3.2.2 Turning On the Transmitter (with Optional Graphic User Interface Screen)	16
3.2.3 Pulling In the Machine Stop Relay	16
3.2.4 Turning Off the Transmitter	16
3.3 MACHINE STOP SWITCH (For Emergency Stopping Only)	16
3.4 POWER/STATUS AND BATTERY LED	17
3.5 OPTIONAL GRAPHIC USER INTERFACE	17
3.6 NORMAL OPERATING MODE WITH STANDARD STATUS LED(S)	17
3.6.1 Transmitters Equipped with Separate Power/Status and Battery LED Indicators	17
3.6.2 Transmitters Equipped with Single Status/Battery LED Indicator	18
3.7 NORMAL OPERATING MODE WITH OPTIONAL GRAPHIC USER INTERFACE	18
3.7.1 Watch Dog Indicator (Spinning Arrow)	19
3.7.2 Command Confirmation	19
3.7.3 Battery Life Indicator	19
3.7.4 Signal Strength Indicator	19
3.7.5 Two-Way Feedback System	19
3.8 JOYSTICKS AND PADDLES/LEVERS	20
3.9 ROTARY SELECTOR SWITCH	20
3.10 AUXILIARY SWITCHES	20
3.11 CONNECTING THE MLTX2 TO A COMPUTER	20
4 TRANSMITTER SETUP	21
4.1 TRANSMITTER SETUP SETTINGS WITH STANDARD STATUS LED	21
4.1.1 RF Channel Setting Override	21
4.1.2 RF Channel Setting Selection	21
4.1.3 IR Configuration Receiver	23
4.1.4 RCP IR Configuration on Transmitters without a Display	24
4.2 USING THE TRANSMITTER IN SETUP MODE (WITH OPTIONAL GRAPHIC USER INTERFACE)	25
4.2.1 Entering Setup Mode	25
4.2.2 Adjusting Settings in Setup Mode	26
5 PROGRAMMING WITH RCP	29
5.1 MLTX2 Configuration Pages	31
5.2 Saving, Downloading, and Reading the Programs and Other RCP Software Functions	36
6 TRANSMITTER RF CHANNEL CONFIGURATION SETTINGS	38
6.1 FCC/ATEX/IECEX STATEMENTS	38

6.2	CHANNEL AND FREQUENCY DESIGNATIONS BY COUNT	39
6.3	433 MHz Telemotive Legacy Channel Set: TMS and TDMA	40
7	GENERAL TROUBLESHOOTING	41
7.1	ASSEMBLY AND REPLACEMENT PARTS	41

1 WARNINGS AND CAUTIONS

Throughout this document **WARNING** and **CAUTION** statements have been deliberately placed to highlight items critical to the protection of personnel and equipment.

WARNING – A warning highlights an essential operating or maintenance procedure, practice, etc. which, if not strictly observed, could result in injury or death of personnel, or long term physical hazards. Warnings are highlighted as shown below:



CAUTION – A caution highlights an essential operating or maintenance procedure, practice, etc. which if not strictly observed, could result in damage to, or destruction of equipment, or loss of functional effectiveness. Cautions are highlighted as shown below:



WARNINGS and CAUTIONS SHOULD NEVER BE DISREGARDED.

The safety rules in this section are not intended to replace any rules or regulations of any applicable local, state, or federal governing organizations. Always follow your local lockout and tagout procedure when maintaining any radio equipment. The following information is intended to be used in conjunction with other rules or regulations already in existence. It is important to read all of the safety information contained in this section before installing or operating the Radio Control System.

2 CRITICAL INSTALLATION CONSIDERATIONS



WARNING

PRIOR TO INSTALLATION AND OPERATION OF THIS EQUIPMENT, READ AND DEVELOP AN UNDERSTANDING OF THE CONTENTS OF THIS MANUAL AND THE OPERATION MANUAL OF THE EQUIPMENT OR DEVICE TO WHICH THIS EQUIPMENT WILL BE INTERFACED. FAILURE TO FOLLOW THIS WARNING COULD RESULT IN SERIOUS INJURY OR DEATH AND DAMAGE TO EQUIPMENT.

FOLLOW YOUR LOCAL LOCKOUT TAGOUT PROCEDURE BEFORE MAINTAINING ANY REMOTE CONTROLLED EQUIPMENT. ALWAYS REMOVE ALL ELECTRICAL POWER FROM THE EQUIPMENT BEFORE ATTEMPTING ANY INSTALLATION PROCEDURES. DE-ENERGIZE AND TAGOUT ALL SOURCES OF ELECTRICAL POWER BEFORE TOUCH-TESTING ANY EQUIPMENT. FAILURE TO FOLLOW THIS WARNING COULD RESULT IN SERIOUS INJURY OR DEATH AND DAMAGE TO EQUIPMENT.

AFTER INSTALLATION BE SURE TO VERIFY THAT THE TRANSMITTER IS NOT INTERFERING WITH OTHER EQUIPMENT IN THE AREA. ALSO VERIFY THAT OTHER EQUIPMENT IS NOT INTERFERING WITH THE TRANSMITTER AND ITS ASSOCIATED EQUIPMENT. FAILURE TO FOLLOW THESE WARNINGS COULD RESULT IN SERIOUS INJURY OR DEATH AND DAMAGE TO EQUIPMENT.



WARNING

SUBSTITUTION OF COMPONENTS MAY IMPAIR INTRINSIC SAFETY.

2.1 GENERAL

Radio controlled material handling equipment operates in several directions. Cranes, hoists, lifting devices and other material handling equipment can be large, and operate at high speeds. Quite frequently, the equipment is operated in areas where people are working in close proximity to the material handling equipment. **The operator must exercise extreme caution at all times.** Workers must constantly be alert to avoid accidents. The following recommendations have been included to indicate how careful and thoughtful actions may prevent injuries, damage to equipment, or even save a life.

2.2 PERSONS AUTHORIZED TO OPERATE RADIO CONTROLLED EQUIPMENT

Only properly trained persons designated by management should be permitted to operate radio controlled equipment.

Radio controlled cranes, hoists, lifting devices and other material handling equipment should not be operated by any person who cannot read or understand signs, notices and operating instructions that pertain to the equipment.

Radio controlled equipment should not be operated by any person with insufficient eyesight or hearing or by any person who may be suffering from a disorder or illness, is taking any medication that may cause loss of equipment control, or is under the influence of alcohol or drugs.

2.3 SAFETY INFORMATION AND RECOMMENDED TRAINING FOR RADIO CONTROLLED EQUIPMENT OPERATORS

Anyone being trained to operate radio controlled equipment should possess as a minimum the following knowledge and skills before using the radio controlled equipment.

The operator should:

- have knowledge of hazards pertaining to equipment operation
- have knowledge of safety rules for radio controlled equipment
- have the ability to judge distance of moving objects
- know how to properly test prior to operation
- be trained in the safe operation of the radio transmitter as it pertains to the equipment being operated
- have knowledge of the use of equipment warning lights and alarms
- have knowledge of the proper storage space for a radio control transmitter when not in use
- be trained in transferring a radio control transmitter to another person
- be trained how and when to report unsafe or unusual operating conditions
- test the transmitter emergency stop and all warning devices prior to operation; testing should be done on each shift, without a load
- be thoroughly trained and knowledgeable in proper and safe operation of the equipment that utilizes the radio control
- know how to keep the operator and other people clear of hazardous areas
- know and follow the local lockout and tagout procedures when servicing radio controlled equipment
- know and follow all applicable operating and maintenance manuals, safety procedures, regulatory requirements, and industry standards and codes

The operator shall not:

- operate the equipment if the direction of travel or function engaged does not agree with what is indicated on the controller
- operate any damaged or malfunctioning equipment
- change any settings or controls without authorization and proper training
- remove or obscure any warning or safety labels or tags
- leave power on the radio controlled equipment when the equipment is not in operation
- operate any equipment using a damaged controller because the unit may be unsafe
- operate manual motions with other than manual power
- operate radio controlled equipment when low battery indicator is on



WARNING

THE OPERATOR SHOULD NOT ATTEMPT TO REPAIR ANY RADIO CONTROLLER. IF ANY PRODUCT PERFORMANCE OR SAFETY CONCERNS ARE OBSERVED, THE EQUIPMENT SHOULD IMMEDIATELY BE TAKEN OUT OF SERVICE AND BE REPORTED TO THE SUPERVISOR. DAMAGED AND INOPERABLE RADIO CONTROLLER EQUIPMENT SHOULD BE RETURNED TO MAGNETEK FOR EVALUATION AND REPAIR. FAILURE TO FOLLOW THIS WARNING COULD RESULT IN SERIOUS INJURY OR DEATH AND DAMAGE TO EQUIPMENT.

2.4 TRANSMITTER UNIT

Transmitter switches should never be mechanically blocked ON or OFF. When not in use, the operator should turn the transmitter OFF. A secure storage space should be provided for the transmitter unit, and the transmitter unit should always be placed there when not in use. This precaution will help prevent unauthorized people from operating the material handling equipment.

Spare transmitters should be stored in a secure storage space and only removed from the storage space after the current transmitter in use has been turned OFF, taken out of the service area and secured.

2.5 PRE-OPERATION TEST

At the start of each work shift, or when a new operator takes control of the equipment, operators should do, as a minimum, the following steps before making lifts with any equipment:

Test all warning devices.

Test all direction and speed controls.

Test all functions.

Test the transmitter machine stop.

2.6 HANDLING BATTERIES



WARNING

KNOW AND FOLLOW PROPER BATTERY HANDLING, CHARGING AND DISPOSAL PROCEDURES. IMPROPER BATTERY PROCEDURES CAN CAUSE BATTERIES TO EXPLODE OR DO OTHER SERIOUS DAMAGE. FAILURE TO FOLLOW THIS WARNING COULD RESULT IN SERIOUS INJURY OR DEATH AND DAMAGE TO EQUIPMENT.

Use only batteries approved by Magnetek for the specific product.

Do not dispose of a battery pack in fire; it may explode.

Do not attempt to open the battery pack.

Do not short circuit the battery.

Do not use sharp tools to remove the battery pack or the cells.

Keep the battery pack environment cool during storage (i.e., not in direct sunlight or close to a heating source).

2.7 BATTERY DISPOSAL

Before disposing of batteries consult local and governmental regulatory requirements for proper disposal procedure.

2.8 CRANE/LIFTING DEVICE SPECIFIC WARNINGS



WARNING

ALL EQUIPMENT MUST HAVE A MAINLINE CONTACTOR INSTALLED AND ALL TRACKED CRANES, HOISTS, LIFTING DEVICES AND SIMILAR EQUIPMENT MUST HAVE A BRAKE INSTALLED. FAILURE TO FOLLOW THIS WARNING COULD RESULT IN SERIOUS INJURY OR DEATH AND DAMAGE TO EQUIPMENT.

AN AUDIBLE AND/OR VISUAL WARNING MEANS MUST BE PROVIDED ON ALL REMOTE CONTROLLED EQUIPMENT AS REQUIRED BY CODE, REGULATION, OR INDUSTRY STANDARD. THESE AUDIBLE AND/OR VISUAL WARNING DEVICES MUST MEET ALL GOVERNMENTAL REQUIREMENTS. FAILURE TO FOLLOW THIS WARNING COULD RESULT IN SERIOUS INJURY OR DEATH AND DAMAGE TO EQUIPMENT.

THE DIRECT OUTPUTS OF THIS PRODUCT ARE NOT DESIGNED TO INTERFACE DIRECTLY TO TWO STATE SAFETY CRITICAL MAINTAINED FUNCTIONS, I.E., MAGNETS, VACUUM LIFTS, PUMPS, EMERGENCY EQUIPMENT, ETC. A MECHANICALLY LOCKING INTERMEDIATE RELAY SYSTEM WITH SEPARATE POWER CONSIDERATIONS MUST BE PROVIDED. FAILURE TO FOLLOW THIS WARNING COULD RESULT IN SERIOUS INJURY OR DEATH OR DAMAGE TO EQUIPMENT.

Cranes, hoists, lifting devices and other material handling equipment can be large, and operate at high speeds.

The operator should:

- continuously watch and monitor status of lifted loads
- know and follow cable and hook inspection procedures

The operator shall not:

- lift or move more than the rated load
- use the crane, hoist or lifting device to lift, support or transport people
- lift or carry any loads over people
- operate the crane, hoist or lifting device unless all persons, including the operator, are and remain clear of the supported load and any potential pinch points
- operate a crane, hoist or lifting device when the device is not centered over the load
- operate a crane, hoist or lifting device if the chain or wire rope is not seated properly in the sprockets, drum or sheave
- leave any load unattended while lifted

2.9 SPECIFIC CONDITIONS OF SAFE USE



WARNING

POTENTIAL ELECTROSTATIC CHARGING HAZARD. SEE INSTRUCTIONS.

The MLTX2 has a maximum measured capacitance from housing and/or accessory to ground of 13pF. When possible, care should be taken to reduce the potential for generation of static electricity, such as:

- Controlling the work environment humidity level to minimize generation of static electricity
- Protect the transmitter from direct airflow
- Touch the transmitter with an insulating object or glove whenever possible
- Use in conjunction with gas detection monitoring
- Do not use in an area that is known to be a static electricity hazard

Additional information on electrostatics can be found in EN TR50404 and IEC/TR60079-32. Joysticks used in the transmitter may have >10% by mass of aluminum. The bulk of this material will be inside the transmitter and will not be accessible.

3 MLTX2 TRANSMITTER STANDARD CONFIGURATION AND OPERATION



BEFORE OPERATING THE TRANSMITTER, FAMILIARIZE YOURSELF WITH ALL SAFETY INFORMATION IN THIS MANUAL, THE CORRESPONDING RECEIVER SYSTEM MANUAL, APPROPRIATE MANUAL SUPPLEMENTS AND ANY OTHER LOCAL, STATE, OR FEDERAL RULES OR REGULATIONS ALREADY IN EXISTENCE. FAILURE TO FOLLOW THIS WARNING COULD RESULT IN SERIOUS INJURY OR DEATH AND DAMAGE TO EQUIPMENT.

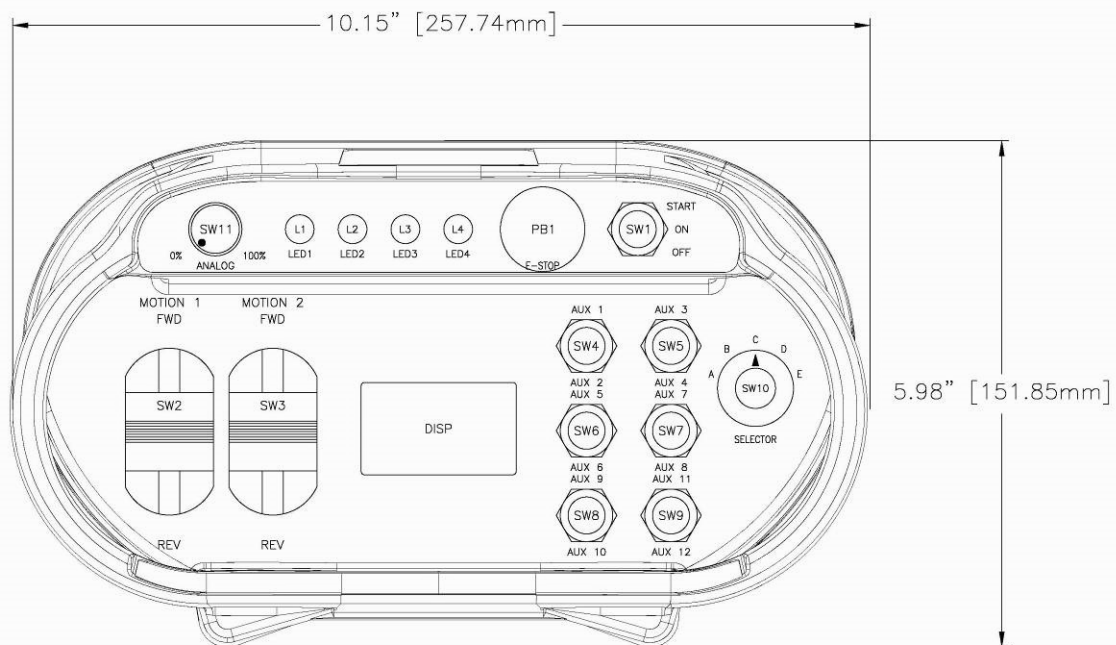

Figure 1: Typical MLTX2 Configuration

3.1 INSTALLING BATTERY PACK

Prior to utilizing the MLTX2 transmitter, the battery pack must be installed.

3.1.1 Approved Batteries for Intrinsically Safe Operation

The MLTX2 transmitter has been tested and approved for intrinsically safe operation with the following AA (LR6) size batteries:

Duracell	MN1500
Duracell	PC1500
Energizer	E91
Panasonic	LR6XWA
Rayovac	815

Use only the above battery manufacturers and part numbers as replacement batteries to maintain intrinsically safe operation.



WARNING

ONLY OPERATE THE TRANSMITTER IN HAZARDOUS ENVIRONMENTS WITH THE APPROVED BATTERIES. FAILURE TO USE THE APPROVED BATTERIES COULD RESULT IN SERIOUS INJURY OR DEATH AND DAMAGE TO EQUIPMENT. ONLY USE FOUR BATTERIES OF THE SAME MANUFACTURER AND MODEL NUMBER.

3.1.2 Intrinsically Safe Alkaline Battery Pack

The Intrinsically Safe MLTX2 comes standard with an intrinsically safe battery pack that holds four disposable AA alkaline batteries.

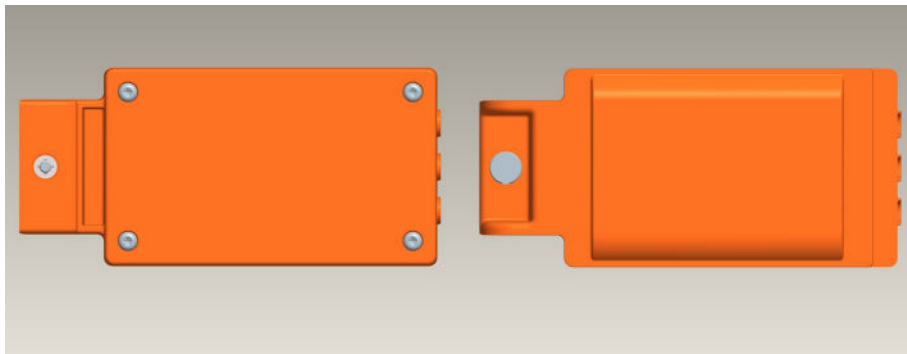

Figure 2: Intrinsically Safe Battery Pack (Top and Bottom Views)

To change the alkaline batteries in the battery pack, loosen the T10 star bit screws completely and remove the battery pack lid. Replace all the batteries with new ones.

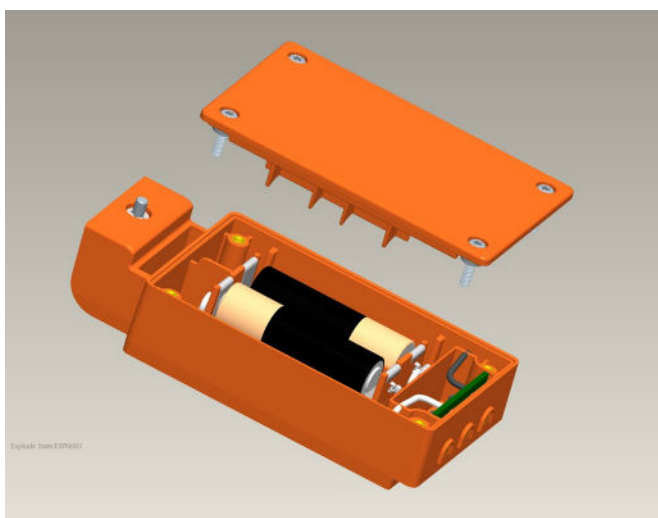

Figure 3: Separated Alkaline Battery Pack

When reinserting the lid onto the outer housing, make sure that the lid aligns with the outer housing and secure all four T10 star bit screws. When placing the battery pack into the MLTX2 battery pocket, ensure that the pack is fully seated and that the thumb screw is tightened down to hold the battery pack in place.

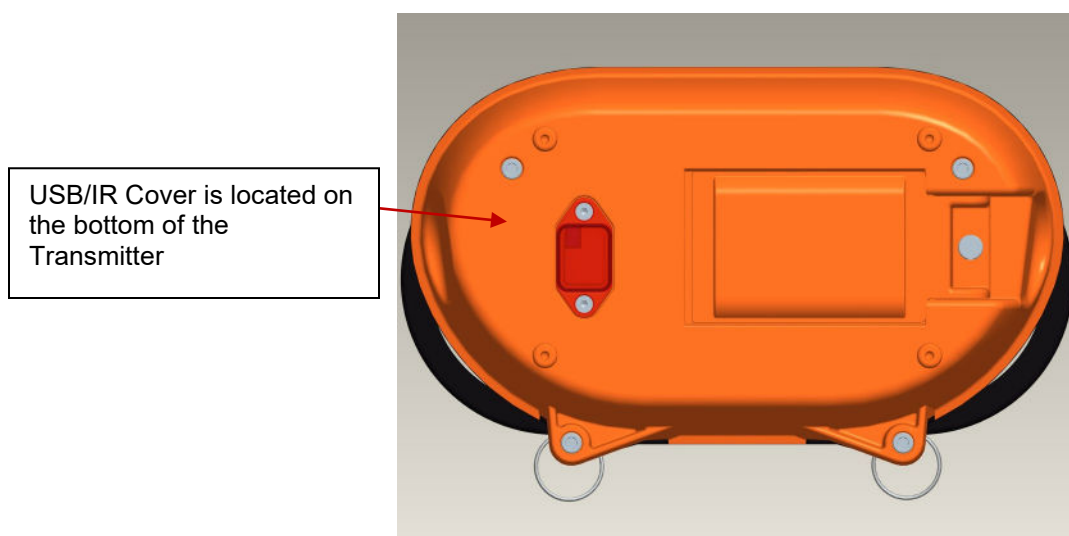

Figure 4: Installation of Battery Pack into MLTX2 Transmitter

NOTE: The Intrinsically Safe battery pack must be secured in place with the thumb screw. Failure to secure the thumb screw will not allow the battery pack to stay securely in place.

3.2 TURNING THE TRANSMITTER ON AND OFF

The MLTX2 uses both a three position toggle switch labeled OFF-ON-START and a Machine Stop switch to turn the transmitter on or off.



Figure 5: Machine Stop Switch and OFF-ON-START Toggle

3.2.1 Turning On the Transmitter (with Standard Status LED Indicator(s))

3.2.1.1 Transmitters Equipped with Separate Power/Status and Battery LED Indicators

First, the Machine Stop switch must be in the raised position (pulled out). Next, push the OFF-ON-START toggle switch to the ON position; the Power/Status LED lights up as a solid green color. Following the Power/Status LED turning on and illuminating, the unit will perform a routine initialization.

During initialization, the MLTX2 scans for any switches or motions that may be on during power up. If any switches or motions are on, the failure will be displayed as a solid red Battery LED, and then the MLTX2 will power itself down.

After a successful initialization, the MLTX2 will enter normal operation mode and display the normal operating status LED indications. See Section 3.6 for more information on the normal operation mode with standard status LED.

3.2.1.2 Transmitters Equipped with Single Status/Battery LED Indicator

First, the Machine Stop switch must be in the raised position (pulled out). Next, push the OFF-ON-START toggle switch to the ON position. The unit will perform a routine initialization.

During initialization, the MLTX2 scans for any switches or motions that may be on during power up. If any switches or motions are on, the failure will power the MLTX2 down.

NOTE: There will be no LED indication of the failure on the Single LED equipped transmitters. If the Battery Status LED does not go into slow blinking mode as detailed in Section 3.6 after 15 seconds, reboot the transmitter by turning the OFF the transmitter and then turning the transmitter back ON.

After a successful initialization, the MLTX2 will enter normal operation mode and display the normal operating status LED indications. See Section 3.6 for more information on the normal operation mode with standard status LED.

3.2.2 Turning On the Transmitter (with Optional Graphic User Interface Screen)

First, the Machine Stop switch must be in the raised position (pulled out). Next, push the OFF-ON-START toggle switch to the ON position; the Magnetek logo appears on the LCD screen. Following the logo screen, the unit will perform a routine initialization.

During initialization, the MLTX2 scans for any switches or motions that may be on during power up. If any switches or motions are on, the failure will be displayed on the screen, and then the MLTX2 will power itself down.

After a successful initialization, the MLTX2 will enter the Normal Operation Mode and display the normal operating screen. See Section 3.7 for more information on the Normal Operation Mode with Optional Graphic User Interface.

NOTE: Holding the OFF-ON-START toggle in the START position for more than 5 seconds will put the device into Setup Mode. For normal use release the START toggle once the Magnetek logo appears. See Section 4.1.4.1 for more information on the Setup Mode.

3.2.3 Pulling In the Machine Stop Relay

Once the MLTX2 has been turned on (as described in Sections 3.2.1 or 3.2.2) and in the Normal Operating Mode, the Machine Stop relay in the receiver can be pulled in by pushing the OFF-ON-START toggle switch to the START position and then releasing.

NOTE: If the unit has a standard status LED, it will illuminate solid red during the transmitter's power down process. Once the power down process is complete, the transmitter will turn off and the status LED will not be on.

NOTE: You must place the OFF-ON-START switch to the ON position, after the unit is powered up, then push to the START position to pull in the Machine Stop relay (for older MLTX2 models, the user will have to position the OFF-ON-START switch into the START position once to start the transmitter and a second time to pull in the Machine Stop relay).

3.2.4 Turning Off the Transmitter

The transmitter can be turned off by pressing the OFF-ON-START toggle switch down to the OFF position. Once turned off, the Machine Stop relay in the receiver is immediately opened.

NOTE: If the unit has the standard separate Power/Status LED and Battery LED, the Battery LED will illuminate solid red during the transmitter's power down process. Once the power down process is complete, the transmitter will turn off and both LEDs will not be on.

NOTE: If the unit has a standard single LED, it will illuminate solid red during the transmitter's power down process. Once the power down process is complete, the transmitter will turn off and the LED will not be on.

NOTE: Depressing the Machine Stop switch will also turn the transmitter off and open the Machine Stop relay in the receiver. See Section 3.3 for more information on the Machine Stop switch.

3.3 MACHINE STOP SWITCH (FOR EMERGENCY STOPPING ONLY)

When the Machine Stop switch is depressed, the Machine Stop relay in the receiver is immediately opened.

Under normal operating conditions, the Machine Stop switch must be in the raised position or the transmitter and system will not operate.

NOTE: The Machine Stop Switch is to be used for emergency stopping only, not for normal system shut down.

3.4 POWER/STATUS AND BATTERY LED

The standard MLTX2 transmitter includes a Power/Status LED to let the operator know that the unit is functioning and Battery LED to indicate that the battery level is low (see Section 3.6.1 for LED indication definitions)

NOTE: Single Status/Battery LED equipped units will indicate that the transmitter is on and the battery level from the single LED (see Section 3.6.2 for LED indication definitions)

3.5 OPTIONAL GRAPHIC USER INTERFACE

The optional LCD screen located at the center of the device provides visual information during the operation of the MLTX2 transmitter. It is used to change configuration settings, confirm commands being operated, provide two-way feedback, and display transmitter diagnostic information such as battery life and signal strength.

The optional graphic user interface replaces the standard status LED when ordered.

3.6 NORMAL OPERATING MODE WITH STANDARD STATUS LED(S)

In normal operating mode, the MLTX2 utilizes the Power/Status and Battery LED(s) to communicate the watch dog timer within the CPU of the transmitter, the machine stop relay status and when the battery level is low.

3.6.1 Transmitters Equipped with Separate Power/Status and Battery LED Indicators

3.6.1.1 Watch Dog Indicator (Steady Slow Blinking Green Power/Status LED)

The blinking Power/Status LED represents the watch dog timer within the CPU of the unit. This indicates that the transmitter is powered on.

NOTE: The Power/Status LED should be continuously blinking at all times. If the LED is not blinking the transmitter will need to be rebooted to operate properly.

3.6.1.2 Machine Stop Relay Indicator (Rapidly Green Blinking Power/Status LED)

When the receiver is online with the transmitter and the machine stop relay is successfully pulled in, the Power/Status LED will rapidly blink green.

NOTE: If the receiver inactivity timer times out, the transmitter will revert back to the watch dog indicating status (steady slow blinking Green Power/Status LED). Following the procedure for pulling in the machine stop relay in Section 3.2.3 will resume the rapidly blinking green Power/Status LED if the machine stop relay is successfully pulled in.

NOTE: This LED function is only available on the 2.4 GHz and 900 MHz equipped transmitters. On 433 MHz equipped transmitters, the watch dog indicator function in Section 3.6.1.1 continues to operate after the machine stop relay is pulled in.

3.6.1.3 Low Battery Level Indicator (Blinking Red Battery LED)

The Battery LED will rapidly flash red when the battery level drops below 10%. The Power/Status LED will continue blinking for the watch dog indicator and machine stop relay indicator status.

NOTE: If using an optional battery pack from what the unit was shipped from the factory with, the low battery level indicator will be inaccurate unless the dip switch settings are set to the correct battery type being used. See Section 3.1.2 for details to properly set the dip switches.

3.6.1.4 Shutdown Sequence Initiated Indicator (Solid Red Battery LED)

When the transmitter is turned off or if the machine stop is depressed, the transmitter will begin its shut down sequence. During the sequence, the Red Battery LED will illuminate solid.

NOTE: When the shutdown sequence is completed, all LEDs will turn off.

3.6.2 Transmitters Equipped with Single Status/Battery LED Indicator

NOTE: For specific LED function details, always refer to the transmitter drawings provided with the system.

3.6.2.1 Watch Dog Indicator (Steady Slow Blinking Red Status/Battery LED)

The slow blinking Battery/Status LED represents the watch dog timer within the CPU of the unit. This indicates that the transmitter is powered on.

NOTE: The Status/Battery LED should be continuously blinking at all times. If the LED is not blinking the transmitter will need to be rebooted to operate properly.

3.6.2.2 Low Battery Level Indicator (Rapidly Blinking Red Status/Battery LED)

The Status/Battery LED will rapidly flash red when the battery level drops below 10%.

NOTE: If using an optional battery pack from what the unit was shipped from the factory with, the low battery level indicator will be inaccurate unless the dip switch settings are set to the correct battery type being used. See Section 3.1.2 for details to properly set the dip switches.

3.6.2.3 Shutdown Sequence Initiated Indicator (Solid Red Battery LED)

When the transmitter is turned off or if the machine stop is depressed, the transmitter will begin its shut down sequence. During the sequence, the red Status/Battery LED may illuminate solid.

NOTE: If the shutdown sequence is started when the LED is not illuminated, the LED will stay in the off state during the shutdown process.

NOTE: When the shutdown sequence is completed, all LEDs will turn off.

3.7 NORMAL OPERATING MODE WITH OPTIONAL GRAPHIC USER INTERFACE

In normal operating mode, the MLTX2 displays real time information relating to the operation of the transmitter on the graphic user interface. Information may include Command Confirmation, Battery Life, Signal Strength, Two-Way Feedback, etc.

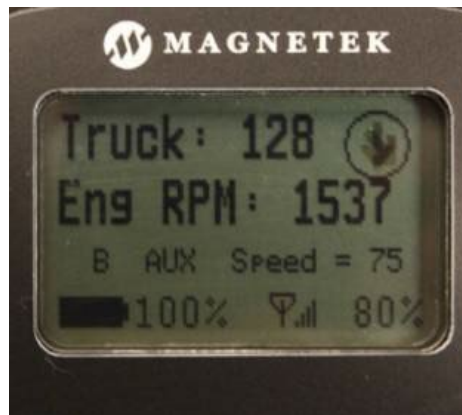

Figure 6: Normal Operating Screen on Graphic User Interface

3.7.1 Watch Dog Indicator (Spinning Arrow)

The spinning arrow represents the watch dog timer within the CPU of the unit.

NOTE: The arrow should be continuously spinning at all times. If the arrow is not spinning, the transmitter will need to be rebooted to operate properly.

3.7.2 Command Confirmation

Each time the user operates a control on the transmitter, a message will be displayed on the graphic user interface screen confirming what is being operated.

For example, if the second paddle is moved to its 4th position in the UP direction the display will show 'MTN2 D1 SP=4'. This translates to 'Motion 2, Direction 1, Speed 4'.

3.7.3 Battery Life Indicator

Remaining battery life is displayed in the bottom left hand corner of the graphic user interface screen.

Battery life is displayed in 5% increments.

NOTE: If using a different battery pack than what the unit originally shipped with, the battery life indicator will be inaccurate unless the dip switch settings are set to the correct battery type being used. See Section 3.1.2 for details to properly set the dip switches.

NOTE: The battery display is only shown when the battery is powering the device. When the device is powered through the optional tethered connection the battery indicator is not displayed and a plug icon is display instead.

NOTE: The battery life indicator will only show accurate battery life when using Magnetek approved battery packs.

3.7.4 Signal Strength Indicator

The Signal Strength Indicator shows the radio signal strength at the receiver.

The Signal Strength Indicator is only available in systems equipped for Two-Way feedback (systems utilizing the 433 MHz frequency band do not have Two-Way feedback available). For such systems, Signal Strength is displayed at the bottom of the graphic user interface screen.

Signal Strength is displayed in 5% increments.

NOTE: On 433 MHz systems, the signal strength indicator will show minimum signal strength regardless of the actual signal strength (systems utilizing the 433 MHz frequency band do not have Two-Way feedback).

3.7.5 Two-Way Feedback System

This option allows the user to view various parameters that may be important to the operation of the equipment on the graphic user interface display screen.

Parameters such as engine RPM, the torque or speed of a drive, temperature, current, or any other useful values can be sent from the receiver and displayed on the transmitter.

NOTE: Systems utilizing the 433 MHz frequency band do NOT have Two-Way feedback available.

3.8 JOYSTICKS AND PADDLES/LEVERS

To activate the desired motor functions, operate the Joystick or Paddle/Lever that corresponds to the desired motion.

To activate higher speed functions for those transmitter models so equipped, operate the Joystick or Paddle/Lever further to activate the desired speed.

3.9 ROTARY SELECTOR SWITCH

The rotary selector switch can be used to select various modes of operation.

A rotary switch can have 2 to 12 positions to select from.

3.10 AUXILIARY SWITCHES

These switches activate special function relays that control items such as grab attachments, magnets, lights, etc.

The auxiliary switches can be momentary or latched.

3.11 CONNECTING THE MLTX2 TO A COMPUTER



WARNING

TO PREVENT IGNITION OF FLAMMABLE OR COMBUSTIBLE ATMOSPHERES, AND TO AVOID COMPROMISING INTRINSIC SAFETY OF THE EQUIPMENT, READ, UNDERSTAND, AND ADHERE TO THE LIVE MAINTENANCE PROCEDURES BELOW.

Only trained Magnetek service personnel are permitted to connect the MLTX2 to a computer. Contact Magnetek Service if service to the product is required.



WARNING

PROGRAMMING THROUGH THE USB PORT IS TO BE DONE SOLELY BY MAGENETK SERVICE PERSONNEL. FAILURE TO FOLLOW THIS WARNING COULD RESULT IN SERIOUS INJURY OR DEATH, AND DAMAGE TO EQUIPMENT.

4 TRANSMITTER SETUP

The transmitter may have settings changed one of three ways.

For units without the optional graphic user interface, the built-in dip switch block can adjust the RF channel, RF Channel Setting Override function, and the battery type. The RF channel and access code can be programmed using the IR configuration link with a compatible receiver. All other settings can only be changed at the factory.

For units with the optional graphic user interface, the Setup Mode can be used to edit configuration settings such as: Access Code, Channel Select, User Code, Transmitter Time Out, Backlight Time Out, Password Enable, Change Password, and more.

NOTE: The IR configuration receiver link can adjust settings on both types of units (with and without the optional graphic user interface), but on units without the optional display the saved channel is only used if the override dip switch is set to ON. If the override dip switch is set to OFF, the dip switch settings set the RF channel.

4.1 TRANSMITTER SETUP SETTINGS WITH STANDARD STATUS LED



WARNING

TO PREVENT IGNITION OF FLAMMABLE OR COMBUSTIBLE ATMOSPHERES, AND TO AVOID COMPROMISING INTRINSIC SAFETY OF THE EQUIPMENT, READ, UNDERSTAND, AND ADHERE TO THE LIVE MAINTENANCE PROCEDURES BELOW.

There are two settings that can be adjusted using the dip switch block: the RF Channel Setting Override setting, and the RF Channel setting. In addition, the access code and channel can be changed using the IR configuration receiver link with a compatible receiver (contact the factory to determine if your receiver is compatible).

4.1.1 RF Channel Setting Override

The dip switch block can enable or disable the RF channel setting dip switch override. Dip switch position number 3 enables the channel from memory function, which enables the transmitter to utilize the channel setting that was set up using the IR configuration receiver option. This dip switch is located on the dipswitch block which is visible through the USB/IR window (see Figure 7). To set the RF channel setting override, reference Figure 8 for dip switch settings for the override function.

4.1.2 RF Channel Setting Selection

The dip switch block can also set the RF channel setting. This dip switch block is the same block used for RF channel setting override. The dip switch block is visible through the USB/IR window (see Figure 7).



WARNING

ONLY PERFORM SETTING CHANGES TO THE DIP SWITCH BLOCK THROUGH THE IR PORT IN A NON-HAZARDOUS ENVIRONMENT OR "SAFE" ZONE. FAILURE TO FOLLOW THIS WARNING COULD RESULT IN SERIOUS INJURY OR DEATH, AND DAMAGE TO EQUIPMENT.

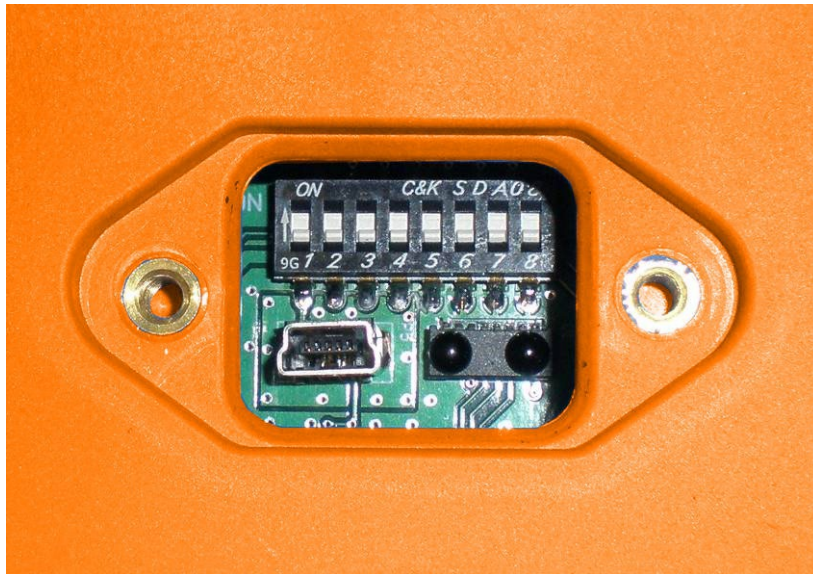

Figure 7: Dip Switch Block as Viewed Through USB/IR Port

NOTE: The dip switch block switches are oriented so that the Off position is next to the number designator and the On position is up or away from the number designator.

Regardless of which radio frequency the transmitter was equipped with the RF channel dip switch settings are the same. Refer to Sections 6.2 and 6.3 for details on the specific RF channel details for the radio frequency that the transmitter is equipped with.

The following figure details the dip switch positions for each RF channel.

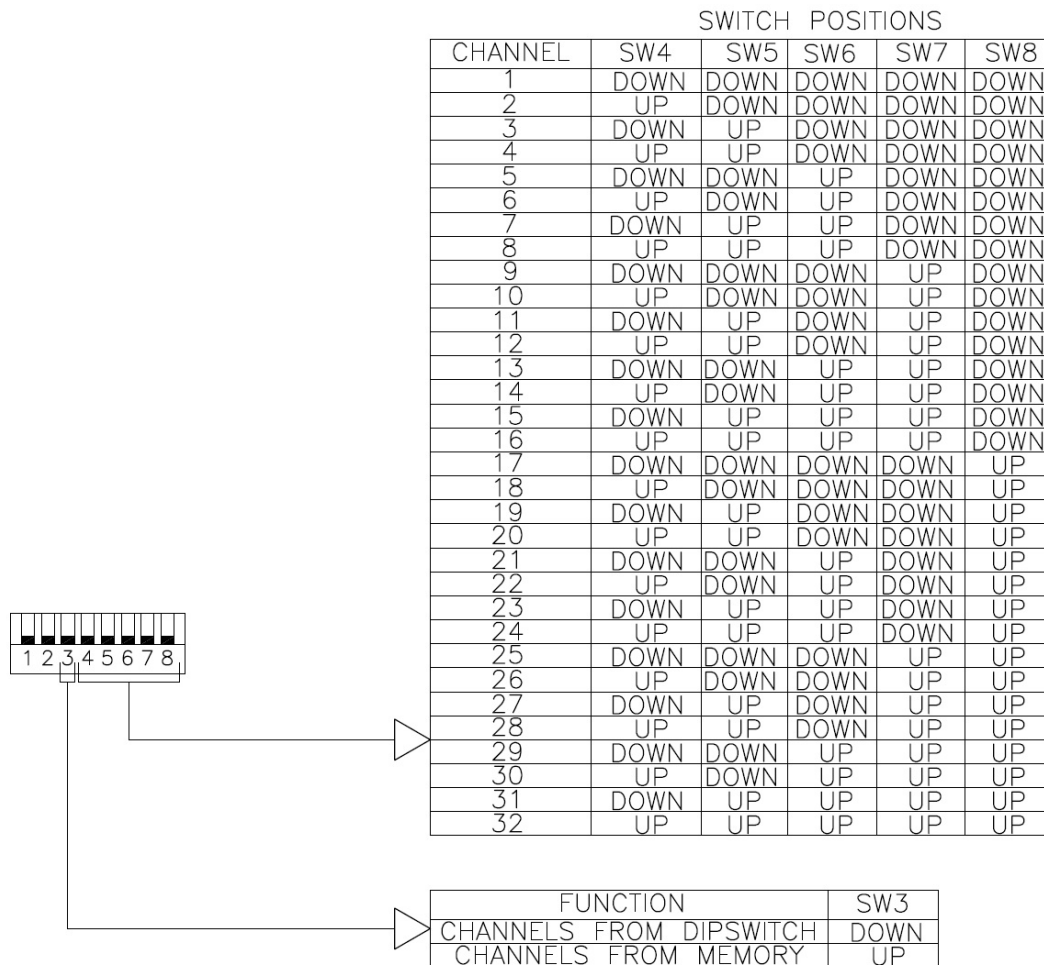

Figure 8: Dip Switch Positions for RF Channel Selection

The dip switch settings will take effect upon the next power cycle of the transmitter.

NOTE: If using the IR configuration receiver function on transmitters NOT equipped with the optional graphic user interface, the channel settings will read from the dip switch positions and not from memory when the channel from memory override function is not enabled. The RF channel set by the IR configuration receiver function will not be used unless the memory override dip switch is set to ON. When the RF channel from memory override is NOT enabled, the dip switch positions set the RF channel used by the transmitter.

NOTE: The transmitters equipped with the optional graphic user interface will read channel settings from memory and will not respond to dip switch changes for the channel setup.

4.1.3 IR Configuration Receiver

The IR Cfg Recv function allows the transmitter to link to a compatible receiver by using IR (contact the factory to determine if your receiver is compatible) and automatically set up the channel and access code to match the linked compatible receiver.

NOTE: If using the IR configuration receiver function on transmitters NOT equipped with the optional graphic user interface, the channel settings will read from the dip switch positions and not from memory when the channel from memory override function is not enabled. The RF channel set by the IR configuration receiver function will not be used unless the memory override dip switch is set to ON. When the RF channel from memory override is NOT enabled, the dip switch positions set the RF channel used by the transmitter.

4.1.3.1 IR Configuration Receiver On Transmitters Equipped with Separate Power/Status and Battery LED Indicators

To utilize the IR configuration receiver function and link to a compatible receiver, push the OFF-ON-START toggle to the Start position and hold for more than 5 seconds. When the transmitter successfully enters the IR configuration mode, the Power/Status and Battery LED(s) will blink alternately continuously. After the LEDs are blinking alternately, point the IR window of the transmitter at the desired receiver to control and momentarily press the OFF-ON-START toggle to the Start position and release.

If the link is successful, the LEDs will stop blinking and the transmitter will shut down. The new settings obtained from the IR configuration function will take effect upon the next power cycle of the transmitter.

If the link is unsuccessful with a compatible receiver, the Power/Status and Battery LED(s) will continue to blink alternately.

To cancel the IR configuration receiver without a successful link, move the OFF-ON-START toggle to the OFF position.

4.1.3.2 IR Configuration Receiver On Transmitters Equipped with Single Status/Battery LED Indicator

To utilize the IR configuration receiver function and link to a compatible receiver, push the OFF-ON-START toggle to the Start position and hold for more than 5 seconds. When the transmitter successfully enters the IR configuration mode, the Status/Battery LED will blink continuously. After the LED is blinking, point the IR window of the transmitter at the desired receiver to control and momentarily press the OFF-ON-START toggle to the Start position and release.

If the link is successful, the LED will stop blinking and the transmitter will shut down. The new settings obtained from the IR configuration function will take effect upon the next power cycle of the transmitter.

If the link is unsuccessful with a compatible receiver, the Status/Battery LED will continue to blink.

To cancel the IR configuration receiver without a successful link, move the OFF-ON-START toggle to the OFF position.

4.1.4 RCP IR Configuration on Transmitters without a Display

4.1.4.1 Transmitters Equipped with Separate Power/Status and Battery LED Indicators

The RCP IR Configuration feature (supported in common code version 6.2 and greater) allows the transmitter configuration to be read and written through the IR Adapter port. Contact customer service to determine if your transmitter is compatible. You will also need to have an IR Adapter available to configure the device.

To utilize the RCP IR configuration feature on compatible transmitters:

1. Push the OFF-ONSTART toggle to the START position and hold for more than 5 seconds.
 - a. When the transmitter successfully enters the IR configuration mode, the Power/Status and Battery LED(s) will blink alternately continuously.
2. After the LEDs are blinking alternately, point the IR adapter at the IR window of the transmitter and use RCP to send and receive data.

*NOTE: This is the same procedure to utilize IR Configuration Pairing with a receiver. The difference is that to pair a transmitter with a receiver you have to press the OFF-ON START toggle. **To communicate with RCP you do not have to press start** (this will place you into a different mode). The device is sitting ready to communicate while the LEDs are blinking.*

4.1.4.2 IR Configuration Receiver on Transmitters Equipped with Single Status/Battery LED Indicator

To utilize the IR configuration receiver function and link to a compatible receiver, push the OFF-ON-START toggle to the Start position and hold for more than 5 seconds. When the transmitter successfully enters the IR configuration mode, the Status/Battery LED will blink continuously. After the LED is blinking, point the IR window of the transmitter at the desired receiver to control and momentarily press the OFF-ON-START toggle to the Start position and release.

If the link is successful, the LED will stop blinking and the transmitter will shut down. The new settings obtained from the IR configuration function will take effect upon the next power cycle of the transmitter.

If the link is unsuccessful with a compatible receiver, the Status/Battery LED will continue to blink.

To cancel the IR configuration receiver without a successful link, move the OFF-ON-START toggle to the OFF position.

4.2 USING THE TRANSMITTER IN SETUP MODE (WITH OPTIONAL GRAPHIC USER INTERFACE)

NOTE: The Setup Mode is only accessed on transmitters equipped with the optional graphic user interface. The units equipped with the standard status LED can only have the settings of the transmitter changed at the factory.

The Setup Mode can be used to edit configuration settings such as: Access Code, Channel Select, User Code, Transmitter Time Out, Backlight Time Out, Password Enable, Change Password, and more.

NOTE: No parameter changes will take effect until the user has selected 'Save and Exit' from the Setup Mode.

4.2.1 Entering Setup Mode

To enter the Setup Mode, first make sure the unit is OFF and the Machine Stop switch is raised. Next, push the OFF-ON-START toggle switch to the START position and hold it in the START position for more than 5 seconds until the setup screen appears.

The user will see a prompt for a four digit password if the password feature is enabled. If no password is enabled, then the adjustments in Section 4.2.2 will be available with no further input required from the user.

NOTE: The password feature is enabled by default from the factory.

Use the Joystick/Paddle to increment/decrement the value and toggle to the START position when finished. If the password is entered correctly, the device will enter Setup Mode. If it is entered incorrectly, the device will power down.

*NOTE: The factory default password to get into the setup menu is **0000**.*

4.2.2 Adjusting Settings in Setup Mode

To navigate through Setup Mode, the Joystick/Paddle designated (MTN 1) and OFF-ON-START switch are used. The Joystick/Paddle cycles through the menus and is also used to change parameters within the menus. Pushing the OFF-ON-START switch to the START position will toggle between the menu and its parameter(s). When adjusting larger values, the speed is dependent on how far the Joystick/Paddle is depressed.

NOTE: No parameter changes will take effect until the user has selected 'Save and Exit' from the Setup Mode.

4.2.2.1 Access Code

The Access Code determines which receiver will be controlled by the transmitter.

The Access Code in the MLTX2 transmitter must match the receiver Access Code or dip switches.

If the Access Codes settings on the receiver and transmitter do not match, no communication will occur.

The Access Code is a 20-bit binary value with a decimal equivalent of 0 - 1048575. It will be displayed as binary or decimal depending on the application.

4.2.2.2 Channel Select

The Channel Select setting determines the frequency on which the MLTX2 is operating.

The user can select channels 1 through 32 which correspond to the frequencies in Sections 6.2 and 6.3.

4.2.2.3 User Code

The User Code setting is a unique identifier that allows the user to select multiple modes when using the same channel. The receiver can be tuned to only 'hear' messages sent from a transmitter with the same user code.

4.2.2.4 Transmitter Timeout

This setting controls the amount of time that the transmitter can be inactive before it automatically shuts off. Factory default is 15 minutes, unless your project specific drawing states otherwise.

The Timeout time can be set from 1 to 60 minutes.

When the unit times out, the transmitter will turn off.

Setting Timeout to 0 disables transmitter timeout.



DO NOT ASSUME THE POWER IS OFF IN THE RECEIVER BECAUSE THE TRANSMITTER IS TURNED OFF. FAILURE TO FOLLOW THIS WARNING COULD RESULT IN SERIOUS INJURY OR DEATH AND DAMAGE TO EQUIPMENT.

4.2.2.5 Backlight Timeout

The Backlight timeout setting controls the amount of time that the backlight will stay on after a command is pressed before it automatically shuts off.

Backlight Timeout can be set from 1 to 30 seconds.

Setting Timeout to disable will disable the backlight.

Setting Timeout to “always on” sets the backlight to be on continuously while the transmitter is on and active.

NOTE: Leaving the backlight on longer will decrease the battery run time and will require more frequent battery replacement.

4.2.2.6 Password Enable

This setting enables or disables the requirement of entering a password into the transmitter to enter setup mode.

When the disabled setting is selected the user will go directly into setup mode without being prompted to enter a password.

Magnetek strongly recommends enabling the setup mode password setting to prevent unauthorized or accidental changes to parameters.

NOTE: The unit is shipped with the password requirement enabled and utilizing the factory default password.

4.2.2.7 Change Password

This allows the user to change the password needed to enter the setup mode.

The password must consist of 4 digits.

4.2.2.8 IR Configuration Receiver

IR Cfg Recv function in the setup allows the transmitter to link to a compatible receiver by using IR (contact the factory to determine if your receiver is compatible) and automatically set up the channel and access code to match the linked compatible receiver.

After selecting this option, point the IR window of the transmitter at the desired receiver to control and momentarily press the OFF-ON-START toggle to the Start position and release. The graphic user interface will display “Attempting” while scanning for the receiver’s IR signal. If the receiver is in range and IR link is made, the message will change to “Success”.

NOTE: The changes to the transmitter’s channel configuration and access code will not be saved until the operator selects the Exit with Save option to exit the Setup Mode.

If the receiver is not in range, the scan will time out and the graphic user interface will display “Failed”. The operator can reposition the transmitter and reattempt to establish the IR link with the receiver by toggling the OFF-ON-START toggle to the Start position multiple times.

NOTE: The access code and channel will not be updated to match the desired receiver until “Success” is displayed. Once “Success” is displayed, subsequent “Failed” messages will not overwrite the access code and channel obtained in the successful IR link until a new successful IR link is made.

The IR configuration function will only update channel and access code information if the receiver and transmitter are programmed at the factory with the same project identification number. If the receiver/transmitter pairing is not programmed with the same project identification number, the graphic

user interface will display “Err Project ID” when an IR link is attempted. The IR link will not be successful and the access code and channel information in the transmitter will not be changed.

If the receiver and transmitter IR pair is not operating in the same frequency band when an IR link is attempted, the graphic user interface will display “Err RF Freq”. The IR link will not be successful and the access code and channel information in the transmitter will not be changed.

4.2.2.9 RCP IR Configuration

The RCP IR Configuration feature (supported in common code version 6.2 and greater) allows the transmitter configuration to be read and written through the IR Adapter port. Contact customer service to determine if your transmitter is compatible. You will also need to have an IR Adapter available to configure the device.

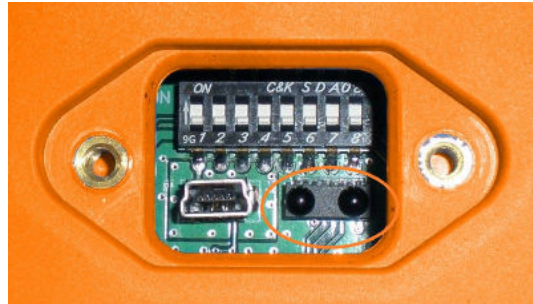

Figure 9: MLTX2 IR Window and LEDs

After selecting this option through, point the IR Adapter at the IR window located on the bottom of the transmitter (as seen in Figure 9.)

The transmitter’s display will show:

```
> RCP IR Cfg
  Ready...
  Press start to exit
```

At this point, the transmitter is ready to send and receive commands from RCP. When finished press the OFF-ON START toggle to exit back to the menu.

NOTE: See RCP User’s Guide for detailed instruction on reading and writing the configuration.

4.2.2.10 Exit Without Save

If the user does not wish to save any of the configuration changes made, the Exit Without Save option can be selected.

NOTE: None of the changes will be saved upon selection of this option. The transmitter will start up with the last saved configuration settings.

4.2.2.11 Exit With Save

Selection of this option saves all changes and exits the Setup Mode.

Upon exit, the device will start up with the new configuration settings.

5 PROGRAMMING WITH RCP

Read the section of the MLTX2 manual regarding additional operational features to familiarize yourself with the features listed below. The MLTX2 transmitter can be programmed using the optional RCP (Radio Control Programmer) software through the programming adapter (inside a HAZLOC area) or directly to the transmitters USB connection outside of the HAZLOC area.

Magnetek RCP software makes the programming of the MLTX2 transmitter easier and allows the programmer to store all of the MLTX2 settings in files for later use or reference. The RCP software also allows the programmer to customize the MLTX2 transmitter display with language descriptions that are project or machine-specific. Help is provided for each function at the bottom of the RCP screen. The RCP software allows you to select frequency, access code, transmitter power, as well as CAN configuration. Follow the steps below:

Install the RCP Software

Install the RCP software onto your computer. The software is self-installing; simply insert the jump drive into any available USB port and follow the onscreen prompts. Refer to the installation instruction sheet for help. You will be prompted to enter an activation code. The code can be found on the jump drive's outer case and on the installation instructions. The software cannot be used without this code.

Run the RCP Software

After installation of the RCP Software, double-click the RCP icon to launch the program.



Click on New Project or Open Project

Select "New Project" if you are creating a new program file. Select "Open Project" if you want to retrieve an existing program file. A list of recent projects will appear under "Open Project." Clicking on one of these will open that project. It is recommended that you create a folder in which to save all programming files.

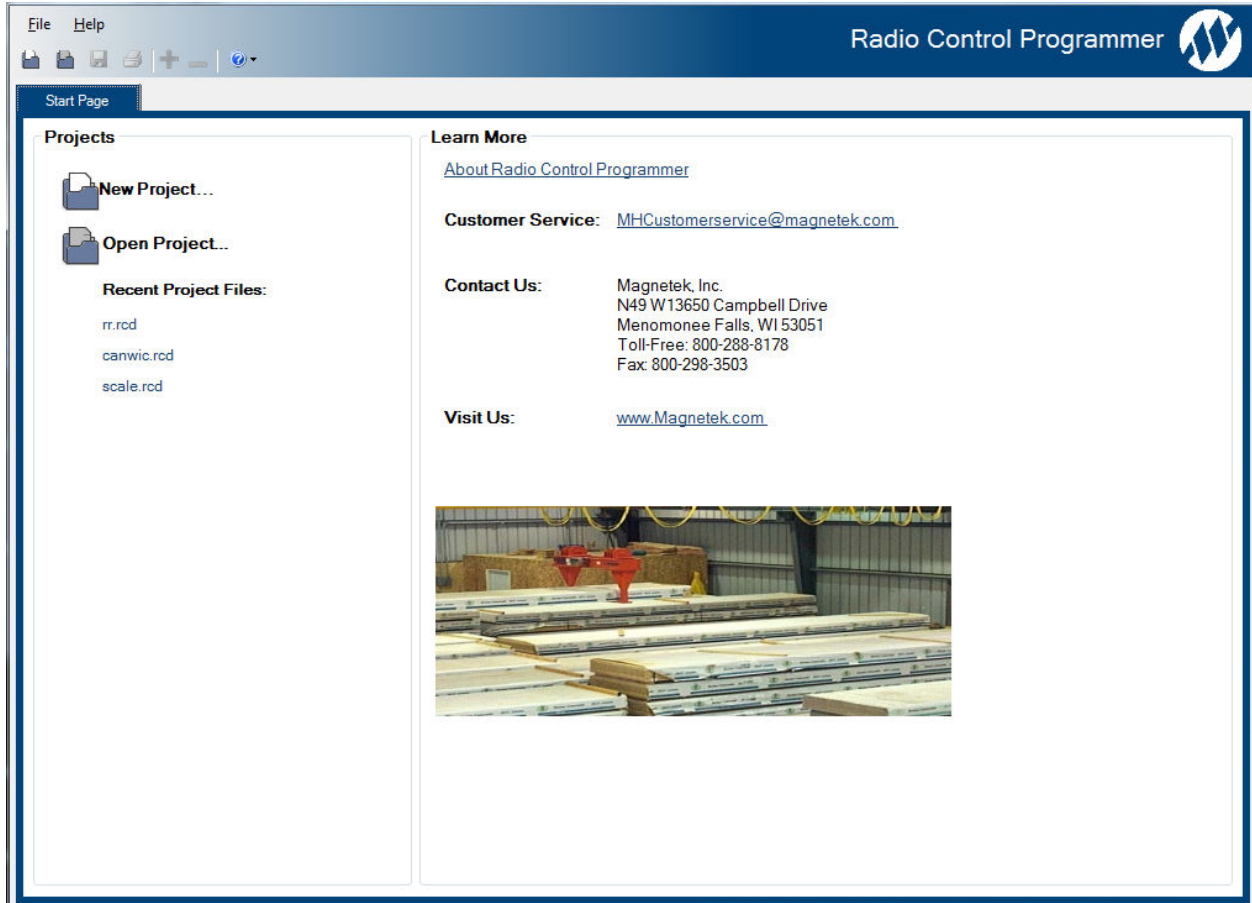

For New Projects, Select Device Type

After the New Projects icon is selected, a menu will open listing the available device types. Select the device type that matches the product you wish to program (selecting a project type will display a picture of the product for verification).

Receive Device Data Checkbox

At the bottom of the New Project window there is a check box that allows the user to automatically download the setting values on the device upon connection.

NOTE: This check box is checked by default.

Having the “Receive Device Data” option checked will cause the program to automatically read the data that is currently on the device upon clicking the Add button.



WARNING

IF "RECEIVE DEVICE DATA" CHECKBOX IS UNCHECKED, THE RCP PROGRAM WILL OVERWRITE ALL SETTING VALUES ON THE DEVICE WITH DEFAULT VALUES AND ANY SETTINGS CHANGED BY THE OPERATOR UPON SENDING THE PROGRAM TO THE DEVICE. ALL STORED VALUE SETTINGS WITHIN THE DEVICE WILL BE REPLACED, INCLUDING ANY PROJECT-SPECIFIC VALUES. MAGNETEK STRONGLY RECOMMENDS THAT THE "RECEIVE DEVICE DATA" CHECKBOX BE LEFT CHECKED.

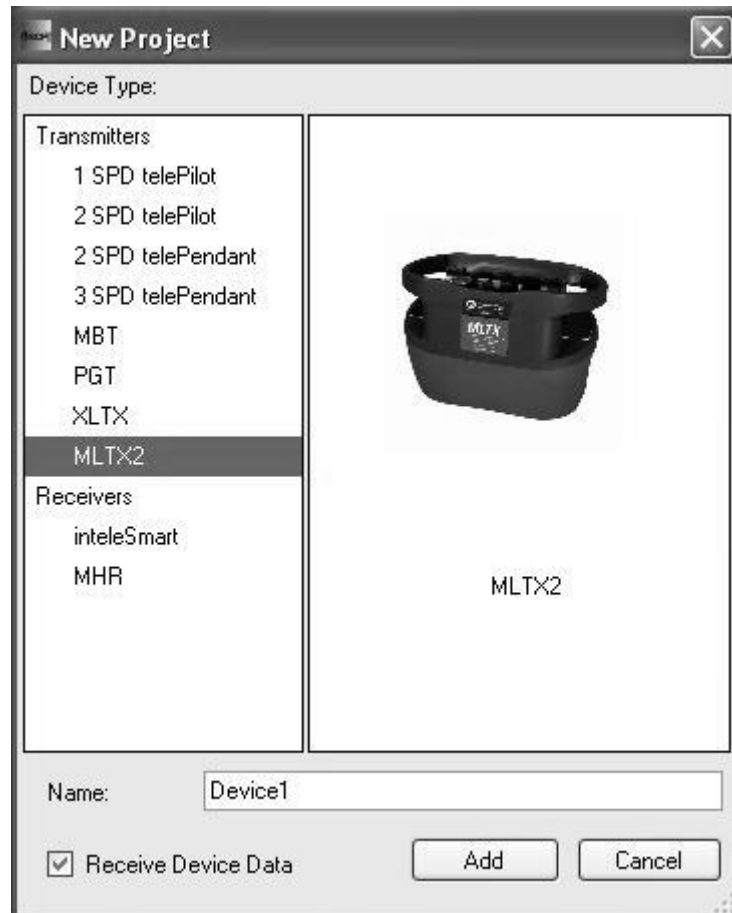

This screen also allows the programmer to create a specific name for the device to help keep track of device settings and changes. It is recommended that a unique name is chosen for each device programmed with RCP.

5.1 MLTX2 CONFIGURATION PAGES

The MLTX2 Transmitter has two configurable pages available to change settings on. The first page allows the configuration of general transmitter settings (Transmitter name, Access code, RF channel, etc.). The second page allows the configuration of the CAN bus network settings for models with the optional CAN connector equipped.

NOTE: HAZLOC systems will not typically have CAN bus networks due to electrical connection hazards.

Unit Info Pages

This page allows the user to view the receiver's Project ID and serial number. The user can modify the transmitter name, access code, RF channel and activate the password. This page may also be used by the user to synchronize the internal clock on the transmitter with the connected PC or manually set the clock/date.

NOTE: Changing any of these details will require a reboot of the MLTX2 after the new information has been sent to the device.

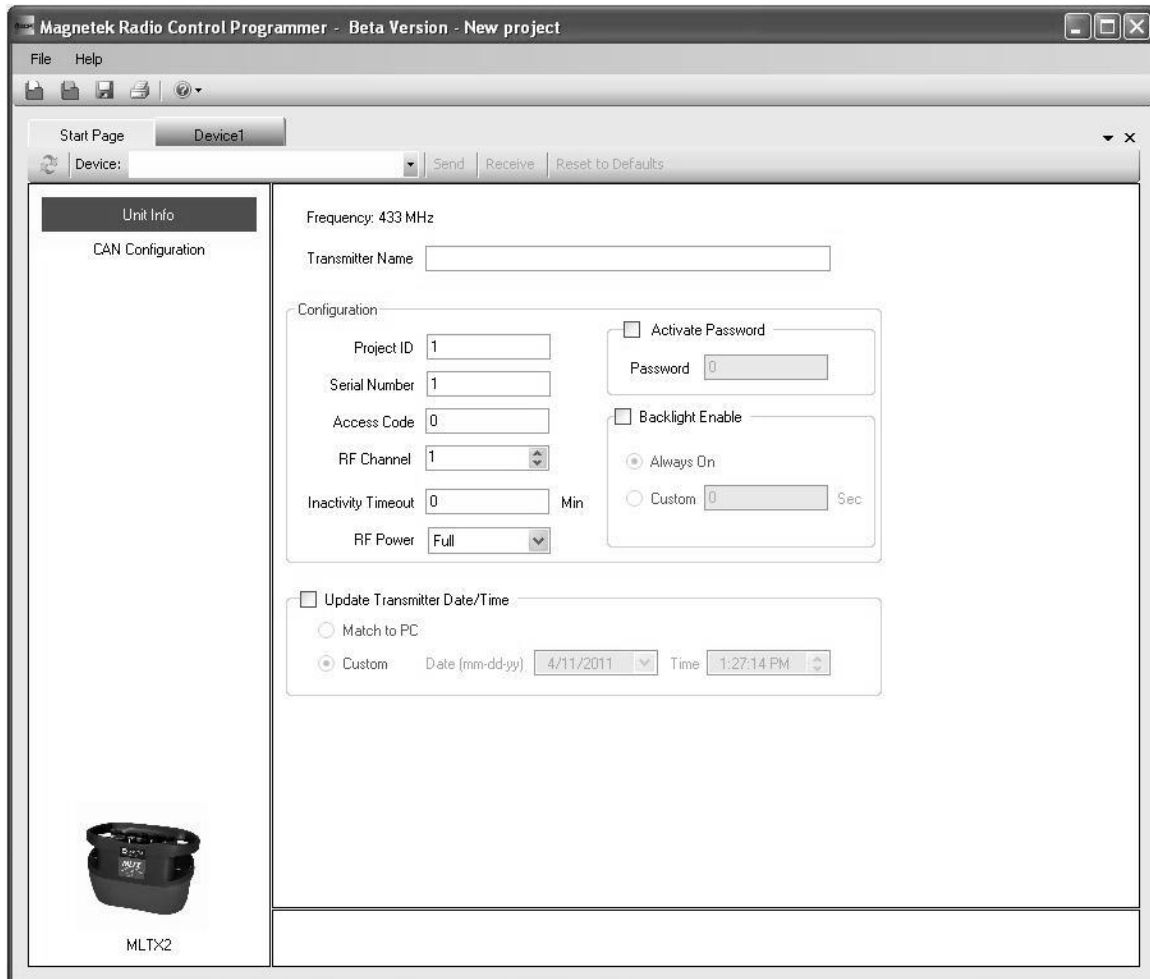

The screenshot shows the Magnetek Radio Control Programmer software interface. The window title is "Magnetek Radio Control Programmer - Beta Version - New project". The interface includes a menu bar with "File" and "Help", a toolbar with icons for file operations, and a main configuration area. The "Unit Info" tab is selected, showing the following fields and options:

- Frequency: 433 MHz
- Transmitter Name: [Text Input Field]
- Configuration section:
 - Project ID: [Text Input Field, value: 1]
 - Serial Number: [Text Input Field, value: 1]
 - Access Code: [Text Input Field, value: 0]
 - RF Channel: [Dropdown Menu, value: 1]
 - Inactivity Timeout: [Text Input Field, value: 0] Min
 - RF Power: [Dropdown Menu, value: Full]
 - Activate Password: [Text Input Field, value: 0]
 - Backlight Enable:
 - Always On
 - Custom: [Text Input Field, value: 0] Sec
 - Update Transmitter Date/Time:
 - Match to PC
 - Custom: Date (mm-dd-yy) [Dropdown Menu, value: 4/11/2011] Time [Dropdown Menu, value: 1:27:14 PM]

An image of the MLTX2 transmitter is shown in the bottom left corner of the configuration area.

Transmitter Name

The transmitter name field allows the user to create a custom name for the transmitter. The name can be up to 16 ASCII characters long.

Project ID

This section displays the Project ID for the unit. The Project ID is set by the factory and cannot be modified by the user.

Serial Number

This section displays the serial number for the unit. The serial number of the unit is set by the factory and cannot be modified by the user.

Access Code

The access code acts as the transmitter address. The transmitter will only transmit commands to receivers with the same address. This feature is selectable by the user.

NOTE: The transmitter must be set with the same access code as the receiver to properly communicate with each other.



WARNING

THE ACCESS CODES IN THE RECEIVER ARE UNIQUE AND FACTORY PRESET. DO NOT CHANGE THESE ACCESS CODES UNLESS YOU ARE REPLACING AN EXISTING RECEIVER AND ITS ACCESS CODE. CHANGING THIS CODE COULD MAKE IT COMMON WITH ANOTHER RECEIVER ACCESS CODE, WHICH COULD MOVE OTHER EQUIPMENT. NO TWO SYSTEMS IN ANY LOCATION SHOULD EVER HAVE THE SAME ACCESS CODES INDEPENDENT OF FREQUENCY. FAILURE TO FOLLOW THIS WARNING COULD RESULT IN SERIOUS INJURY OR DEATH, AND DAMAGE TO EQUIPMENT.

RF Channel

The RF channel is user-selectable through the pull-down menu. This function is used to prevent interference with other radio devices. The user-selectable channels for 400 MHz and 900 MHz systems are 1 through 32. See Section 6.2 for channel frequency details.

Inactivity Timeout

The transmitter can be set to turn off after a period of time when no controls are activated. To restart the transmitter, the OFF-ON-START switch must be cycled through the start position. The factory default setting for the inactivity timeout is 15 minutes.

RF Power

The RF transmitting power of the unit is user-selectable through the pull-down menu. This function is used to reduce the operating range of the transmitter from the equipment being operated. The user-selectable options for RF power are MAX, 50%, 25% and MIN.

Activate Password

The password is used to restrict access to the configuration menu on the MLTX2. Having an active password prevents accidental changes to the transmitter.

Please familiarize yourself with this section before programming your password.

If you choose to enable the password function, you can create a new password by selecting a four digit numerical password using numbers from 0 to 9. Be sure to write this password down in a safe place for future reference.



WARNING

ALWAYS REMEMBER TO STORE THE PASSWORD IN A SECURE LOCATION FOR ACCESS IF THE PASSWORD IS LOST OR FORGOTTEN. ONCE THE TRANSMITTER IS PROGRAMMED WITH A PASSWORD, THERE IS NO WAY TO DEFEAT THE PASSWORD WITHOUT USING THE RCP SOFTWARE TO EITHER READ THE PASSWORD OR REPROGRAM A NEW PASSWORD.



WARNING

THIS PASSWORD FUNCTION IS NOT TO BE USED AS A SECURITY DEVICE. THE PURPOSE OF THIS FUNCTION IS TO PREVENT ACCIDENTAL CHANGES TO THE TRANSMITTER SETTINGS. THE BEST FORM OF SECURITY IS ALWAYS TO LOCK UP THE TRANSMITTER WHEN NOT IN SERVICE. FAILURE TO FOLLOW THIS WARNING COULD RESULT IN SERIOUS INJURY OR DEATH AND DAMAGE TO EQUIPMENT.

The password default setting is to be disabled during initial programming by the RCP software. To enable password protection, check the box next to the phrase “Activate password.”



WARNING

NOT ENABLING THE PASSWORD FUNCTION ALLOWS THE TRANSMITTER SETTINGS TO BE MODIFIED BY ANY UNAUTHORIZED USERS. IMPROPER TRANSMITTER SETTINGS COULD RESULT IN SERIOUS INJURY OR DEATH AND DAMAGE TO EQUIPMENT.

Backlight Enable

This section allows the user to enable the LCD display backlight and select the period of time after transmitter activity that the backlight stays on.

The user has the option to check the “Always On” check boxed for backlight timeout. If this box is checked, the backlight will remain on continuously while the transmitter is active.

NOTE: The longer the backlight is turned on, the shorter the transmitter battery life will be.

The user can also enable the backlight to turn off or timeout after a period of time - the user can select the custom field and enter in the time (in seconds) that the backlight should be lit. The range of values is 1 to 30 seconds.

Update Transmitter Date/Time

This feature allows the user to reset the internal clock on the transmitter to the correct date and time. The user can select to match the clock on the PC that is connected to the unit or select a custom date and time.

CAN Configuration Page

This page allows the user to modify the CAN bus network communication settings.

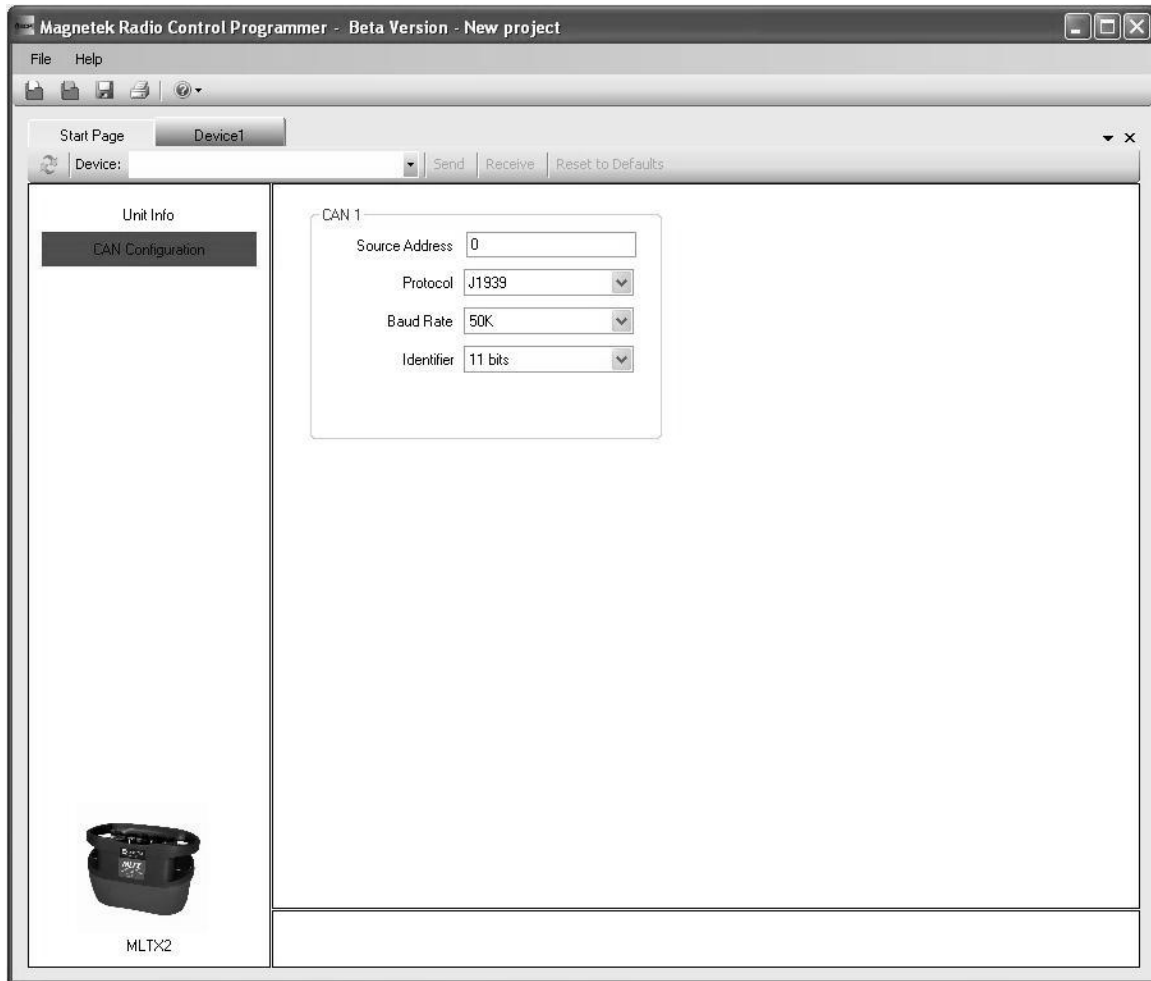

Source Address

This is the address that the MLTX2 will use as the source address when transmitting messages on the CAN bus network.

Protocol

This pull down menu allows the user to modify the communication protocol for the CAN bus network. The user can select from the following options:

- J1939
- CAN Open
- Parker ICP
- High Country Tek DN
- OEM Controls

Baud Rate

This pull down menu allows the user to modify the communication speed of the CAN bus network. The user selectable options are 50k, 125k, 250k, and 500k.

Identifier

This pull down menu allows the user to select between an 11 bits or 29 bits identifier.

5.2 SAVING, DOWNLOADING, AND READING THE PROGRAMS AND OTHER RCP SOFTWARE FUNCTIONS



CAUTION

TO PROGRAM OR READ DATA FROM THE MLTX2, THE TRANSMITTER MUST BE TURNED ON.

Saving the Programming File

Once programming is complete click the file tab at the top of the RCP screen to open the file menu. File location and name can be selected from this menu. Old files can be deleted, called up, modified and renamed by this same menu.

Sending a Program to the MLTX2



WARNING

AFTER EVERY PROGRAMMING OF THE TRANSMITTER, TEST THE UNIT BY UTILIZING THE APPROPRIATE RECEIVER. IF THE RECEIVER DOES NOT RESPOND, DO NOT ACTIVATE A FUNCTION BUTTON! THE TRANSMITTER MAY HAVE INCORRECT PROGRAMMING. RE-CHECK THE PROGRAMMING IN THE TRANSMITTER AND RETEST. AFTER ACTIVATION OF THE RECEIVER, FUNCTIONALLY TEST ALL COMMANDS ON THE TRANSMITTER BY INITIALLY JOGGING THE BUTTONS, THEN WITH A FULL MOVEMENT BEFORE RETURNING TO SERVICE. FAILURE TO FOLLOW THIS WARNING COULD RESULT IN SERIOUS INJURY OR DEATH AND DAMAGE TO EQUIPMENT.



WARNING

PROGRAMMING THROUGH THE USB PORT IS TO BE DONE SOLELY BY MAGENETK SERVICE PERSONNEL. FAILURE TO FOLLOW THIS WARNING COULD RESULT IN SERIOUS INJURY OR DEATH, AND DAMAGE TO EQUIPMENT.

To send a program file to a MLTX2 Transmitter

1. In an area outside of the HAZLOC, utilize the programming cable from the computer to the RCP programming adapter and turn the radio Transmitter on.

2. Click the “send” button on the RCP screen. A dialog box will pop up confirming that you want to proceed. Check the box marked “I accept,” and then click the button “Continue send to radio.” On-screen prompts will confirm that the receiver has been programmed or if there are any issues.
3. Data will need to be sent separately for the Unit Info and CAN Configuration screens.

Receiving (Reading) the MLTX2 Programming

To read a program file from the MLTX2 Transmitter:

1. Utilize the programming cable from the computer to the RCP programming adapter and turn the radio Transmitter on
2. Click “Receive” and follow on-screen prompts.
3. RCP will confirm reception and automatically display current programming in the MLTX2 unit.

Reading the RCP Software Version

1. Select “Help”.
2. Select “About”.
3. The RCP Software Version number will be displayed.

Resetting MLTX2 Back to Factory Default Settings

1. Select “Reset to Defaults” button.
2. A dialog box will pop up confirming that you want to proceed. Click the button “OK” to restore the factory default settings. On-screen prompts will confirm that the transmitter has been reset to defaults or if there are any issues.
3. Power cycle the MLTX2 transmitter to implement the factory default values.

NOTE: Resetting the system back to factory defaults only restores the factory settings for the CAN configuration settings. All other settings will not be altered.

6 TRANSMITTER RF CHANNEL CONFIGURATION SETTINGS

The RF channel can be set via the dip switch block when not through the RCP IR settings (depending on DIP1 SW3). Section 6.2 shows the channels and protocols available for each transmitter radio frequency option.

6.1 FCC/ATEX/IECEX STATEMENTS

Compliance Statement (Part 15.19)

This device complies with Part 15 of FCC rules.

Operation is subject to the following two conditions:

1. This device may not cause harmful interference, and
2. This device must accept any interference received, including interference that may cause undesired operation.

Warning (Part 15.21)

Changes or modifications not expressly approved by the party responsible for compliance should void the user's authority to operate the equipment.

This portable transmitter with its antenna complies with FCC's RF exposure limits for general population/uncontrolled exposure.

See "XLTX MLTX2 Transmitter ATEX IECEx Information Sheet", Magnetek PN 198-80202-0003, for details regarding the hazardous location approvals for this product.

6.2 CHANNEL AND FREQUENCY DESIGNATIONS BY COUNT

433 MHz

Channel Count	Channel Designator	Actual Frequency
01)	01	433.000 MHz
02)	02*	433.050 MHz
03)	03*	433.100 MHz
04)	04*	433.150 MHz
05)	05*	433.200 MHz
06)	06*	433.250 MHz
07)	07*	433.300 MHz
08)	08*	433.350 MHz
09)	09*	433.400 MHz
10)	10*	433.450 MHz
11)	11*	433.500 MHz
12)	12*	433.550 MHz
13)	13*	433.600 MHz
14)	14*	433.650 MHz
15)	15*	433.700 MHz
16)	16*	433.750 MHz
17)	17*	433.800 MHz
18)	18*	433.850 MHz
19)	19*	433.900 MHz
20)	20*	433.950 MHz
21)	21*	434.000 MHz
22)	22*	434.050 MHz
23)	23*	434.100 MHz
24)	24*	434.150 MHz
25)	25*	434.200 MHz
26)	26*	434.250 MHz
27)	27*	434.300 MHz
28)	28*	434.350 MHz
29)	29*	434.400 MHz
30)	30*	434.450 MHz
31)	31*	434.500 MHz
32)	32*	434.550 MHz

Table 1.A

Channels marked with * are approved for use in Australia

900 MHz

Channel Count	Channel Designator	Actual Frequency
01)	1	903.30 MHz
02)	2	906.30 MHz
03)	3	907.80 MHz
04)	4	909.30 MHz
05)	5	912.30 MHz
06)	6	915.30 MHz
07)	7	919.80 MHz
08)	8	921.30 MHz

09)	A	902.30 MHz
10)	B	904.10 MHz
11)	C	904.30 MHz
12)	D	905.10 MHz
13)	E	905.50 MHz
14)	F	905.70 MHz
15)	G	906.60 MHz
16)	H	908.70 MHz
17)	I	908.90 MHz
18)	J	909.10 MHz
19)	K	910.10 MHz
20)	L	910.70 MHz
21)	M	911.00 MHz
22)	N	911.20 MHz
23)	O	912.00 MHz
24)	P	914.20 MHz
25)	Q	914.40 MHz
26)	R	914.60 MHz
27)	S	914.80 MHz
28)	T	915.80 MHz
29)	U	917.40 MHz
30)	V	923.20 MHz
31)	W	927.00 MHz
32)	X	927.30 MHz

Table 1.B

6.3 433 MHZ TELEMOTIVE LEGACY CHANNEL SET: TMS AND TDMA

Channel Count	Channel Designator	Actual Frequency
01)	AK01	439.8 MHz
02)	AK02	439.6 MHz
03)	AK03	439.4 MHz
04)	AK04	439.2 MHz
05)	AK05	439.0 MHz
06)	AK06	438.8 MHz
07)	AK07	438.6 MHz
08)	AK08	438.4 MHz
09)	AK09	438.2 MHz
10)	AK10	438.0 MHz
11)	AK11	437.8 MHz
12)	AK12	437.6 MHz
13)	AK13	437.4 MHz
14)	AK14	437.2 MHz
15)	AK15	437.0 MHz
16)	AK16	436.8 MHz
17)	AK17	436.6 MHz
18)	AK18	436.4 MHz
19)	AK19	436.2 MHz
20)	AK20	436.0 MHz
21)	AKA00	433.125 MHz
22)	AKA01	433.325 MHz
23)	AKA02	433.525 MHz
24)	AKA03	433.725 MHz
25)	AKA04	433.925 MHz
26)	AKA05	434.125 MHz
27)	AKA06	434.325 MHz
28)	AKA07	434.525 MHz
29)	AKA08	434.725 MHz
30)	AK38	432.4 MHz
31)	AK50	430.0 MHz

Table 2

7 GENERAL TROUBLESHOOTING

Problems	Possible Reasons	Suggestions
Transmitter will not turn on	Batteries are dead or installed backwards; battery holder is damaged.	Replace the batteries and confirm they are installed according to the polarity marking in the battery pack. Inspect all battery pack contacts for damage. When installing the battery pack into the MLTX2, confirm it is installed with the label facing out.
	Transmitter is failing switch scan	Be sure all switches and motions are in the off position on startup. See Section 3.2 for more info.
	Transmitter Machine Stop Switch is down or pressed	Be sure the Machine Stop switch is pulled up.
Transmitter will not communicate with the receiver	Incorrect system RF channel	Make sure the transmitter and receiver unit are both set to the same RF channel.
	Incorrect system access code	Make sure the transmitter and receiver both have the same access code.
	System out of range	Make sure that the startup procedure is initiated within 300 feet from the receiver location. If equipped with the Signal Strength Indicator, make sure the level is greater than 0%.
	The antenna on the receiver is missing, damaged, or improperly installed.	Inspect the antenna on the receiver for damage and try to locate the antenna in a location that is visible when operating the equipment at all times.

7.1 ASSEMBLY AND REPLACEMENT PARTS

If your transmitter ever needs repair, we always recommend that you have Magnetek perform the repair. If you need to refer to a parts list, refer to the transmitter drawing that was included in the shipment of your transmitter. Please contact Magnetek's service department at 1.866.MAG.SERV for information regarding parts and service.

EU Declaration of Conformity Certificate

For the following equipment:

Product : XLTX/MLTX2 Series Radio Remote Control
Multiple Listee Model No. : XLTX, MLTX2
Manufacturer's Name: : Magnetek, Inc.
Manufacturer's Address : N49 W13650 Campbell Drive
Menomonee Falls, WI 53051 USA

The undersigned hereby declares on behalf of Magnetek, that the above-referenced product, to which this declaration relates, is in conformity with the provisions of the following directives:

- CE Mark Directive (93/68/EEC)
- Machinery Safety Directive (2006/42/EC)
- Radio Equipment Directive (2014/53/EU)
- EMC Directive (2014/30/EU)
- ROHS2 Directive (2011/65/EU)
- ATEX II Directive (2014/34/EU)

The standards relevant for the evaluation of the product referenced above conformity to the directive requirements are as follows:

EN 301 489-1 v1.9.2:2011-09
EN 301 489-17 v2.1.1:2009-05
EN 300 220-2: v3.1.1:2017-02
EN ISO 13849-1:2008
EN 61010-1:2010
EN 13557:2003+A2:2008
EN 12100:12100
EN 60529:1992
EN 60079-0:2018
EN 60079-11:2012
EN 60950-1:2006 +A11:2009 +A1:2010 +A12:2011 +A2:2013

ATEX specific information:

Product is in conformity with the EC type examination certificate: **DEMKO 14 ATEX 1350799X**
For Equipment Group and Category: **II 1 G**
Type of Protection: **ia**
Explosion Group: **IIC**
Temperature Class: **T3 & T4**

Issued by the notified body:

UL International
Lyskær 8
DK-2730 Herlev
Kenn-Nr. / ident. No. 0539

The product has been manufactured, finally inspected and tested under a quality system that has been approved by the notified body:

UL, LLC
2500 West Dundee Road
Northbrook, IL 60062

The European contact for technical documentation is:

Ian Knight
STAHL CraneSystems, Ltd.
Unit 2 Forge Mills Park
Station Road
Coleshill
Warwickshire B46 1JH
United Kingdom

Per Annex II.B of the Machinery Directive (2006/42/EC):

The machinery, product, assembly or sub-assembly covered by this Declaration of Conformity must not be put into service until the machinery into which it is to be incorporated has been declared in conformity with the provisions of the applicable Directive(s). This statement is only necessary where the product is to be incorporated into a machine or system (e.g. a safety component).

Signature of Authorized Person:



Ed Butte
Global Product Manager - Controls
Columbus McKinnon Corporation
Date of Issuance: 2 February 2022

Intrinsically Safe XLTX Transmitter
Radio Remote Control
Technical Manual
March 2022



COLUMBUS MCKINNON FAMILY OF BRANDS

