



Flex 4EX and 6EX Systems

Radio Control Equipment Instruction Manual



Part Number: 191-00193-3200_R00
July 2018

©Copyright 2018 Magnetek Material Handling

Page Intentionally Left Blank

Table of Contents

1	Introduction	6
1.1	Product Manual Safety Information	7
1.2	Warnings and Cautions	8
2	Critical Installation Considerations	9
2.1	General	9
2.2	Persons Authorized to Operate Radio-Controlled Cranes	9
2.3	Safety Information and Recommended Training for Radio-Controlled Equipment Operators	10
2.4	Transmitter Unit	11
2.5	Pre-Operation Test	11
2.6	Batteries	12
2.7	Battery Handling	12
2.8	Battery Charging	12
2.9	Battery Disposal	12
2.10	Specific System Warnings	13
3	General System Information	14
3.1	Transmitter	14
3.1.1	External Illustration	14
3.1.2	Internal Illustration	16
3.2	Receiver Unit	18
3.2.1	External Illustration	18
3.2.2	Internal Illustration	19
4	Function Settings	20
4.1	Transmitter Handset	20
4.1.1	System Channel Settings	20
4.1.2	Pushbutton Functions with LED Displays	21
4.1.3	Channel Change via Pushbuttons	25
4.1.4	Optional 4-Digit Security Code	26
4.1.5	I-CHIP	27
4.2	Receiver Unit	28
4.2.1	System Channel Settings	28
4.2.2	Output Relay Configurations	29
4.2.3	Receiver Auto-Scanning Settings	32
4.2.4	Dipswitch Settings	33
4.2.5	Jumper Settings	35
4.2.6	I-CHIP Programming Port	36
4.2.7	Fuse Ratings	36
5	System Channels Table	37
6	Receiver Installation	38
6.1	Output Relay Contact Diagrams	38
6.1.1	Flex 4EX	38
6.1.2	Flex 6EX	39
6.2	Pre-installation Precautions	39
6.3	Step-by-Step Installation	40
6.4	System Testing	41
7	Operating Procedure	42
7.1	Transmitter Operation	42
7.1.1	General Operating Procedure	42
7.1.2	A/B Selector Pushbutton Operating Procedure	43
7.1.3	3rd Speed Pushbutton Operating Procedure	43
7.1.4	Automatic Channel Scanning Operating Procedure	44

7.1.5	Changing Transmitter Batteries	44
7.2	Status Light Indicators and Warnings.....	45
7.2.1	Transmitter STATUS Light Indication	45
7.2.2	Receiver STATUS Light Indication	46
7.2.3	Receiver SQ Light Indication	46
7.2.4	Receiver POWER Light Indication.....	46
7.2.5	Receiver COM Light Indication	46
7.3	Troubleshooting Tips.....	47
8	System Specifications.....	48

SERVICE INFORMATION

Your New Radio System

Thank you for your purchase of Magnetek's Flex EX radio remote control system. Magnetek has set a whole new standard in radio-remote performance, dependability and value with this unique new line of Flex EX system.

If your product ever needs modification or service, please contact one of our representatives at the following locations:

U.S. Service Information

For questions regarding service or technical information contact:

1-866-MAG-SERV
(1-866-624-7378)

International Service

262-783-3500

World Headquarters:

Magnetek, Material Handling
N49 W13650 Campbell Drive
Menomonee Falls, WI 53051

Telephone: 800-288-8178
Website: www.magnetek.com
E-mail: mhcustomerservice@magnetek.com

Fax Numbers:

Main: 800-298-3503
Sales: 262-783-3510
Service: 262-783-3508

Canada Service Information:

161 Orenda Road
Unit 1
Brampton, Ontario
L6W 1W3 Canada
Phone: 800-792-7253
Fax: 905-828-5707
416-424-7617 (24/7 Service pager)

EU Market Contact:

Brian Preston
Magnetek (UK) Ltd.
Unit 3 Bedford Business Centre
Mile Road
Bedford, MK42 9TW UK
Phone: +44-1234-349191

© 2018 MAGNETEK

All rights reserved. This notice applies to all copyrighted materials included with this product, including, but not limited to, this manual and software embodied within the product. This manual is intended for the sole use of the person(s) to whom it was provided, and any unauthorized distribution of the manual or dispersal of its contents is strictly forbidden. This manual may not be reproduced in whole or in part by any means whatsoever without the expressed written permission of MAGNETEK.

1 Introduction

The Flex radio remote control systems are designed for control of industrial equipment and machinery such as overhead traveling cranes, jib cranes, gantry cranes, tower cranes, electric hoists, winches, monorails, conveyor belts, mining equipment and other material handling equipment where wireless control is preferred.

Each Flex system consists of a transmitter handset and receiver unit. Other standard-equipped accessories include transmitter waist belt, spare transmitter power key, clear vinyl pouch, "AA" alkaline batteries, compass direction decal sheet and user's manual.

List of notable features includes:

- **62 user-programmable channels** – Advanced synthesized RF controls with 62 built-in channels; there are no more fixed channels and fragile quartz crystals to break.
- **Automatic channel scanning receiver** – No more hassle of climbing up the crane to change receiver channels.
- **More than 1 million unique ID codes (20-bit)** – Each and every Flex system has its own unique ID codes and serial number; these never repeat.
- **Advanced controls** – The Flex system utilizes advanced microprocessor controls with 32-bit CRC and Hamming Code, which provide ultra-fast, safe, precise, and error-free encoding and decoding.
- **Unique I-CHIP design** – The I-CHIP functions in a way that is very similar to SIM cards used on mobile phones, with the ability to transfer system information and settings from one transmitter to another without the hassle of resetting the spares.
- **Reliable pushbuttons** – The in-house-designed pushbuttons with gold-plated contacts are rated for more than 1 million press cycles.
- **Low power consumption** – Requires only two "AA" alkaline batteries for more than 100 hours of operating time between replacements.
- **Ultra-durable nylon and fiberglass composite enclosures** – Highly resistant to breakage and deformation, even in the most abusive environments.
- **Full compliance** – All systems fully comply with the FCC Part-15 Rules, European Directives (Safety, EMC, RED, and Machinery), and Industry Canada Specifications (IC).

1.1 Product Manual Safety Information

Magnetek, Inc. (Magnetek) offers a broad range of radio remote control products, control products and adjustable frequency drives, and industrial braking systems for overhead material handling applications. This manual has been prepared by Magnetek to provide information and recommendations for the installation, use, operation and service of Magnetek's material handling products and systems (Magnetek Products). Anyone who uses, operates, maintains, services, installs or owns Magnetek Products should know, understand and follow the instructions and safety recommendations in this manual for Magnetek Products.

The recommendations in this manual do not take precedence over any of the following requirements relating to proper equipment operation:

- Instructions, manuals, and safety warnings of the manufacturers of the equipment where the radio system is used,
- Plant safety rules and procedures of the employers and the owners of facilities where the Magnetek Products are being used,
- Regulations issued by the Occupational Health and Safety Administration (OSHA),
- Applicable local, state or federal codes, ordinances, standards and requirements, or
- Safety standards and practices for the specific industry.

This manual does not include or address the specific instructions and safety warnings of these manufacturers or any of the other requirements listed above. It is the responsibility of the owners, users and operators of the Magnetek Products to know, understand and follow all of these requirements. It is the responsibility of the owner of the Magnetek Products to make its employees aware of all of the above listed requirements and to make certain that all operators are properly trained. **No one should use Magnetek Products prior to becoming familiar with and being trained in these requirements and the instructions and safety recommendations in this manual.**

WARRANTY INFORMATION

For information on Magnetek's product warranties by product type, please visit www.magnetek.com.

1.2 Warnings and Cautions

Throughout this document WARNING and CAUTION statements have been deliberately placed to highlight items critical to the protection of personnel and equipment.



WARNING indicates a potentially hazardous situation which, if not avoided, could result in death or serious injury.



CAUTION indicates a potentially hazardous situation which, if not avoided, could result in minor or moderate injury. It may also be used to alert against unsafe practices.

NOTE: A NOTE statement is used to notify people of installation, operation, programming, or maintenance information that is important, but not hazard-related.

WARNINGS and CAUTIONS SHOULD NEVER BE DISREGARDED.

The safety rules in this section are not intended to replace any rules or regulations of any applicable local, state, or federal governing organizations. Always follow your local lockout and tagout procedure when maintaining any radio equipment. The following information is intended to be used in conjunction with other rules or regulations already in existence. It is important to read all of the safety information contained in this section before installing or operating the Radio Control System.

2 Critical Installation Considerations



Prior to installation and operation of this equipment, read and develop an understanding of the contents of this manual and the operation manual of the equipment or device to which this equipment will be interfaced. Failure to follow this warning could result in serious injury or death and damage to equipment.

All equipment must have a mainline contactor installed and all tracked cranes, hoists, lifting devices and similar equipment must have a brake installed. Failure to follow this warning could result in serious injury or death and damage to equipment.

An audible and/or visual warning means must be provided on all remote-controlled equipment as required by code, regulation, or industry standard. These audible and/or visual warning devices must meet all governmental requirements. Failure to follow this warning could result in serious injury or death and damage to equipment.

Follow your local lockout/tagout procedure before maintaining any remote-controlled equipment. Always remove all electrical power from the crane, hoist, lifting device or similar equipment before attempting any installation procedures. De-energize and tagout all sources of electrical power before touch-testing any equipment. Failure to follow this warning could result in serious injury or death and damage to equipment.

The direct outputs of this product are not designed to interface directly to two state safety critical maintained functions, i.e., magnets, vacuum lifts, pumps, emergency equipment, etc. A mechanically locking intermediate relay system with separate power considerations must be provided. Failure to follow this warning could result in serious injury or death or damage to equipment.

2.1 General

Radio-controlled material handling equipment operates in several directions. Cranes, hoists, lifting devices and other material handling equipment can be large, and can operate at high speeds. The equipment is often operated in areas where people are working in close proximity to the material handling equipment. **The operator must exercise extreme caution at all times.** Workers must constantly be alert to avoid accidents. The following recommendations have been included to indicate how careful and thoughtful actions may prevent injuries, prevent damage to equipment, or even save a life.

2.2 Persons Authorized to Operate Radio-Controlled Cranes

Only properly trained persons designated by management should be permitted to operate radio-controlled equipment.

Radio-controlled cranes, hoists, lifting devices and other material handling equipment should not be operated by any person who cannot read or understand signs, notices and operating instructions that pertain to the equipment.

Radio-controlled equipment should not be operated by any person with insufficient eyesight or hearing or by any person who may be suffering from a disorder or illness that may cause them to lose control of the equipment, is taking any medication that may cause loss of equipment control, or is under the influence of alcohol or drugs.

2.3 Safety Information and Recommended Training for Radio-Controlled Equipment Operators

Anyone being trained to operate radio-controlled equipment should possess as a minimum the following knowledge and skills before using the radio-controlled equipment.

The operator should:

- have knowledge of hazards pertaining to equipment operation
- have knowledge of safety rules for radio-controlled equipment
- have the ability to judge distance of moving objects
- know how to properly test prior to operation
- be trained in the safe operation of the radio transmitter as it pertains to the crane, hoist, lifting device or other material handling equipment being operated
- have knowledge of the use of equipment warning lights and alarms
- have knowledge of the proper storage space for a radio control transmitter when not in use
- be trained in transferring a radio control transmitter to another person
- be trained how and when to report unsafe or unusual operating conditions
- test the transmitter emergency stop and all warning devices prior to operation; testing should be done on each shift, without a load
- be thoroughly trained and knowledgeable in proper and safe operation of the crane, hoist, lifting device, or other material handling equipment that utilizes the radio control
- know how to keep the operator and other people clear of lifted loads and to avoid “pinch” points
- continuously watch and monitor status of lifted loads
- know and follow cable and hook inspection procedures
- know and follow the local lockout and tagout procedures when servicing radio-controlled equipment
- know and follow all applicable operating and maintenance manuals, safety procedures, regulatory requirements, and industry standards and codes

The operator shall not:

- lift or move more than the rated load
- operate the material handling equipment if the direction of travel or function engaged does not agree with what is indicated on the controller
- use the crane, hoist or lifting device to lift, support or transport people
- lift or carry any loads over people
- operate the crane, hoist or lifting device unless all persons, including the operator, are and remain clear of the supported load and any potential pinch points
- operate a crane, hoist or lifting device when the device is not centered over the load
- operate a crane, hoist or lifting device if the chain or wire rope is not seated properly in the sprockets, drum or sheave
- operate any damaged or malfunctioning crane, hoist, lifting device or other material handling equipment

- change any settings or controls without authorization and proper training
- leave any load unattended while lifted
- remove or obscure any warning or safety labels or tags
- leave power on the radio-controlled equipment when the equipment is not in operation
- operate any material handling equipment using a damaged controller because the unit may be unsafe
- operate manual motions with other than manual power
- operate radio-controlled equipment when low battery indicator is on



The operator should not attempt to repair any radio controller. If any product performance or safety concerns are observed, the equipment should immediately be taken out of service and be reported to the supervisor. Damaged and inoperable radio controller equipment should be returned to Magnetek for evaluation and repair. Failure to follow this warning could result in serious injury or death and damage to equipment.

2.4 Transmitter Unit

Transmitter switches should never be mechanically blocked on or off. When not in use, the operator should turn the transmitter off. A secure storage space should be provided for the transmitter unit, and the transmitter unit should always be placed there when not in use. This precaution will help prevent unauthorized people from operating the material handling equipment.

Spare transmitters should be stored in a secure storage space and only removed from the storage space after the current transmitter in use has been turned off, taken out of the service area and secured.

2.5 Pre-Operation Test

At the start of each work shift, or when a new operator takes control of the crane, operators should do, as a minimum, the following steps before making lifts with any crane or hoist:

Test all warning devices.

Test all direction and speed controls.

Test the transmitter emergency stop.

2.6 Batteries



Know and follow proper battery handling, charging and disposal procedures. Improper battery procedures can cause batteries to explode or do other serious damage. Failure to follow this warning could result in serious injury or death and damage to equipment.

2.7 Battery Handling

Use only batteries approved by Magnetek for the specific product.

Do not dispose of a battery pack in fire; it may explode.

Do not attempt to open the battery pack.

Do not short-circuit the battery.

For intrinsically safe environments, only use specified Magnetek intrinsically safe batteries.

Keep the battery pack environment cool during charging operation and storage (i.e., not in direct sunlight or close to a heating source).

2.8 Battery Charging

For those transmitters equipped with battery chargers, please familiarize all users with the instructions of the charger before attempting to use.

Do not attempt to charge non-rechargeable battery packs.

Avoid charging partially discharged rechargeable batteries to help prolong battery cycle life.

Avoid charging the battery pack for more than 24 hours at a time.

Do not charge batteries in a hazardous environment.

Do not short the charger.

Do not attempt to charge a damaged battery.

Use only Magnetek-approved chargers for the appropriate battery pack.

Do not attempt to use a battery that is leaking, swollen or corroded.

Charger units are not intended for outdoor use. Use only indoors.

2.9 Battery Disposal

Before disposing of batteries, consult local and governmental regulatory requirements for proper disposal procedure.

2.10 Specific System Warnings

Below are some specific operating safety tips that should be strictly followed when operating a Flex EX system:

- Check the Status LED on the transmitter for any signs of low battery power (**see Section 7.2 on page 45**).
- Check the Status LED on the transmitter for any signs of irregularities (**see Section 7.2 on page 45**).
- Make sure the system is not set to the same channel as any other Flex systems in use within a distance of 300 meters (900 feet).
- Never operate a crane or equipment with two transmitter handsets at the same time unless they are programmed to do so.

3 General System Information

3.1 Transmitter

3.1.1 External Illustration

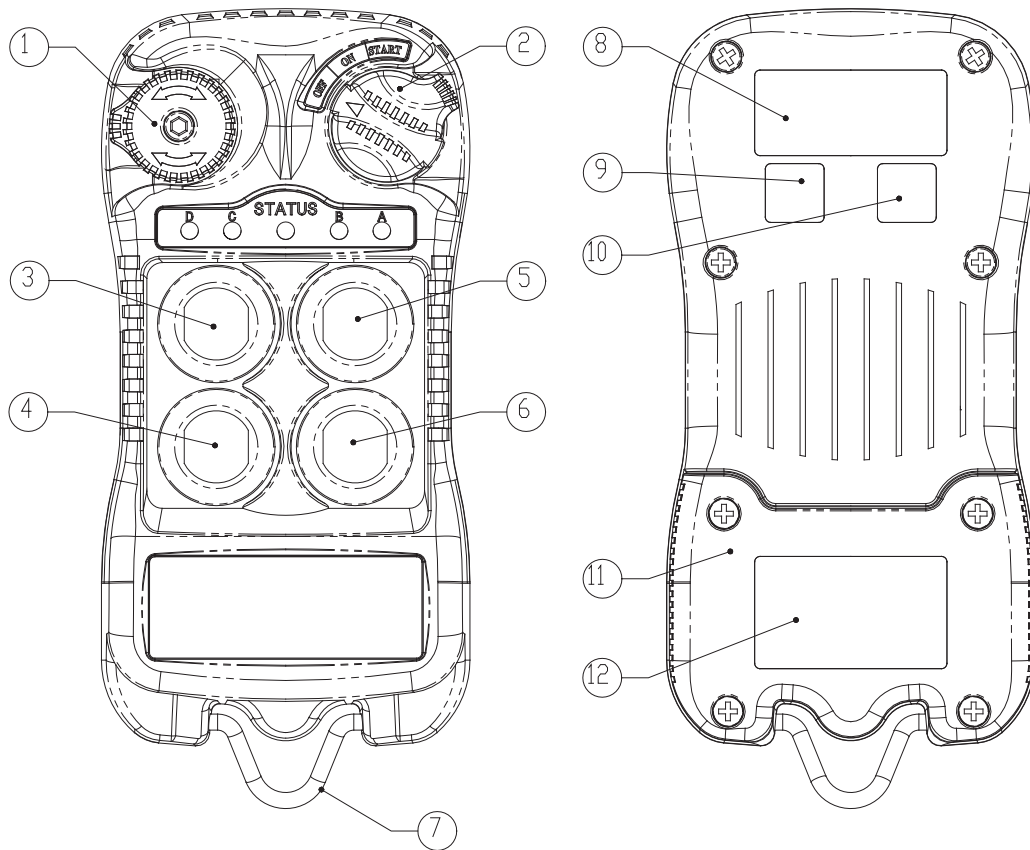

Fig. 1: Flex 4EX

- | | | | |
|----|----------------------------|-----|--------------------|
| 1. | Emergency Stop Button | 7. | Strap Ring |
| 2. | Removable Power Key Switch | 8. | System Information |
| 3. | Pushbutton #2 | 9. | System Channel |
| 4. | Pushbutton #4 | 10. | Crane Number |
| 5. | Pushbutton #1 | 11. | Battery Cover |
| 6. | Pushbutton #3 | 12. | FCC Information |

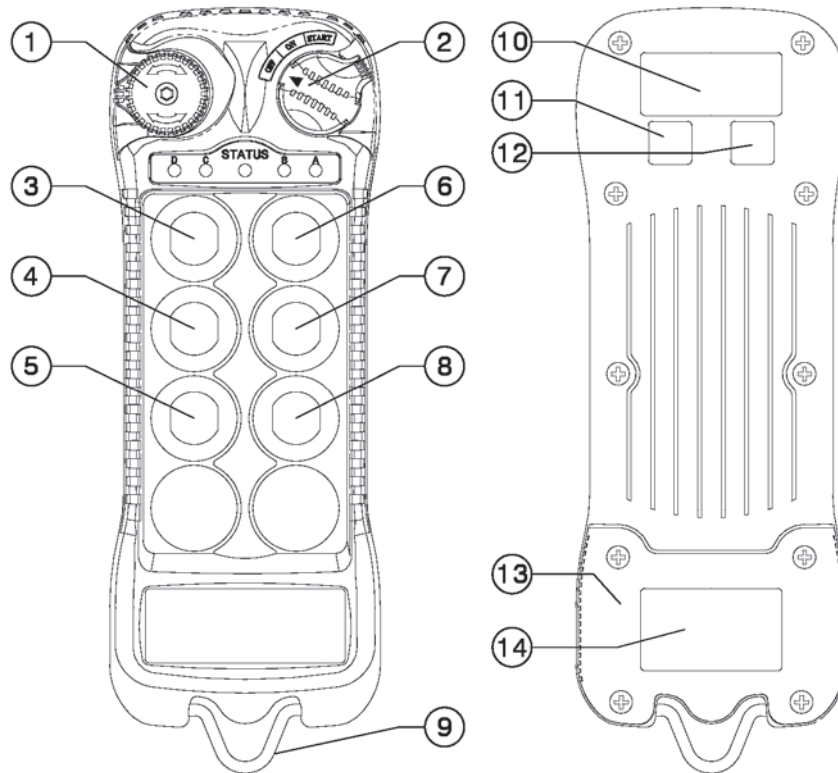

Fig. 2: Flex 6EX

- | | | | |
|----|----------------------------|-----|--------------------|
| 1. | Emergency Stop Button | 8. | Pushbutton #5 |
| 2. | Removable Power Key Switch | 9. | Strap Ring |
| 3. | Pushbutton #2 | 10. | System Information |
| 4. | Pushbutton #4 | 11. | System Channel |
| 5. | Pushbutton #6 | 12. | Crane Number |
| 6. | Pushbutton #1 | 13. | Battery Cover |
| 7. | Pushbutton #3 | 14. | FCC Information |

3.1.2 Internal Illustration

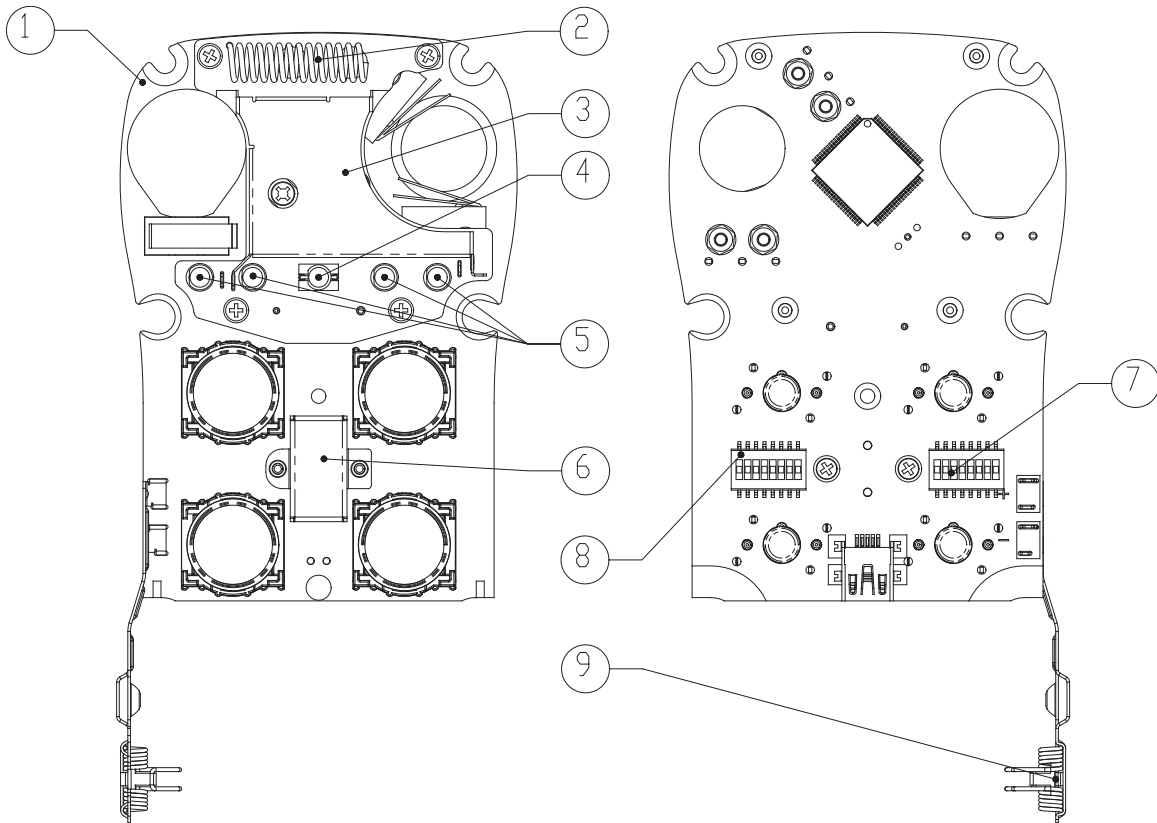

Fig. 3: Flex 4EX

- | | | | |
|----|-----------------------|----|---------------------------|
| 1. | Encoder Board | 6. | I-CHIP |
| 2. | Aerial Antenna | 7. | Function Dipswitch |
| 3. | Transmitting Module | 8. | Channel Dipswitch |
| 4. | Status LED Display | 9. | Battery Contact Mechanism |
| 5. | Function LED Displays | | |

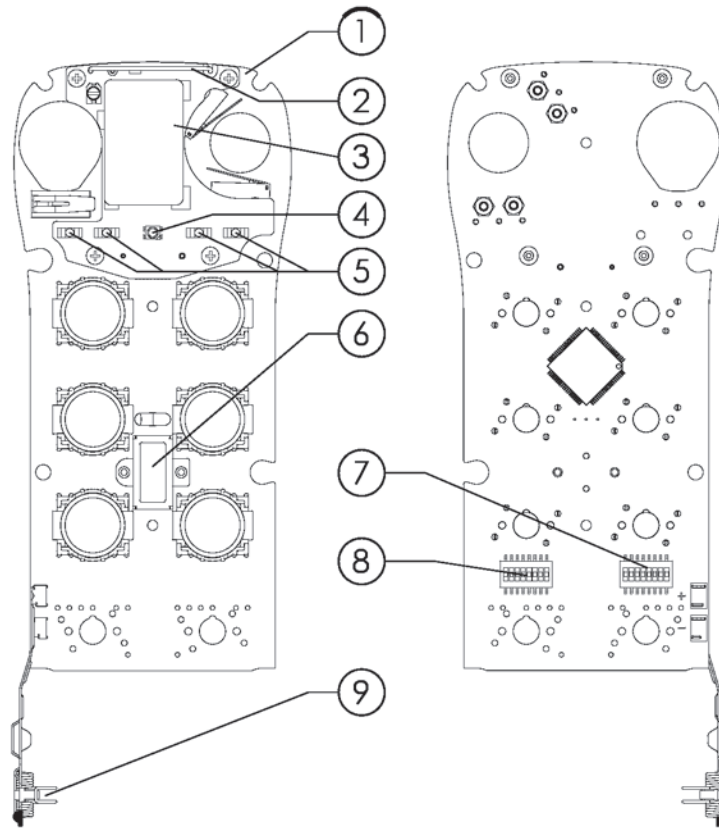

Fig. 4: Flex 6EX

- | | | | |
|----|-----------------------|----|---------------------------|
| 1. | Encoder Board | 6. | I-CHIP |
| 2. | Aerial Antenna | 7. | Function Dipswitch |
| 3. | Transmitting Module | 8. | Channel Dipswitch |
| 4. | Status LED Display | 9. | Battery Contact Mechanism |
| 5. | Function LED Displays | | |

3.2 Receiver Unit

3.2.1 External Illustration

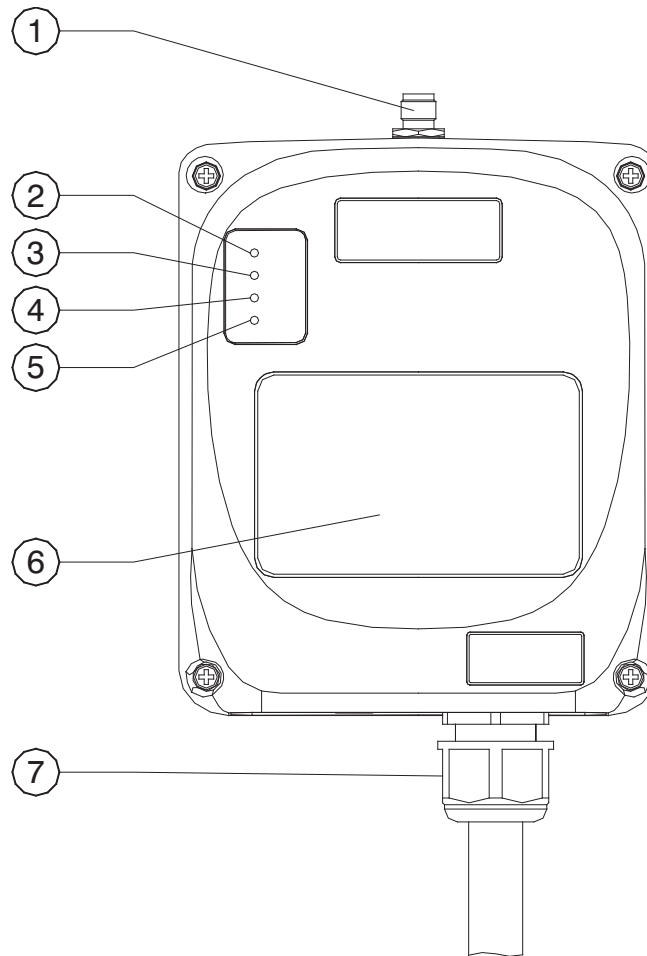

Fig. 5

- | | | | |
|----|----------------------------------|----|------------------------|
| 1. | External Antenna Jack (optional) | 5. | COM LED Display |
| 2. | Power LED Display | 6. | Output Contact Diagram |
| 3. | Status LED Display | 7. | Cord Grip |
| 4. | SQ LED Display | | |

3.2.2 Internal Illustration

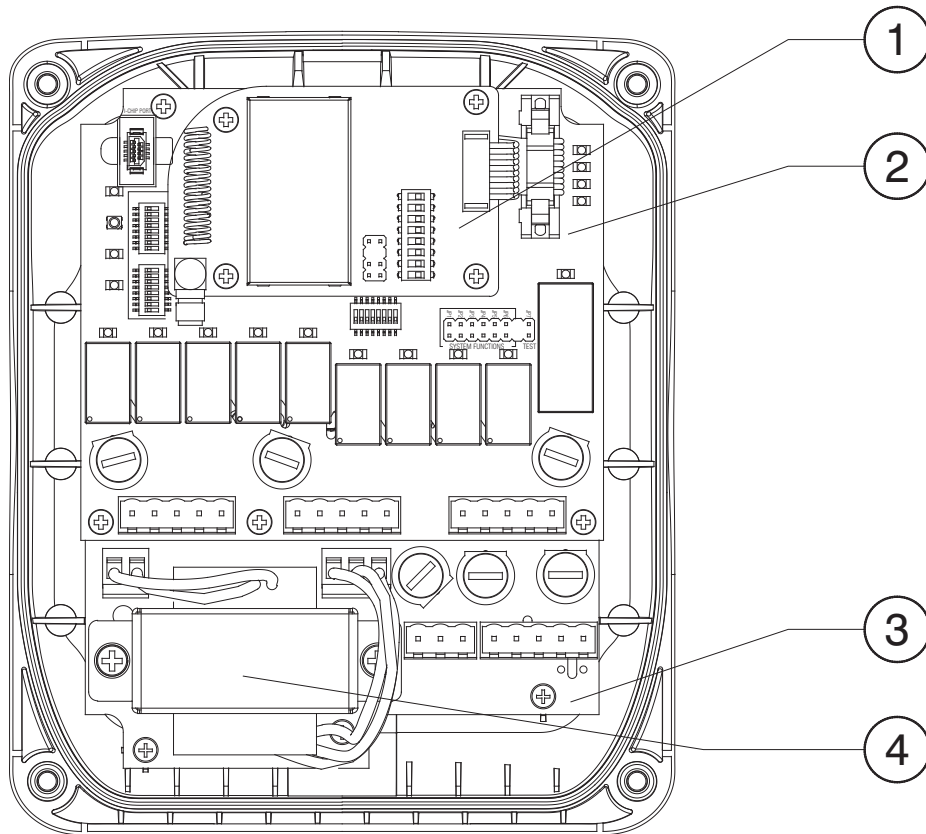

Fig. 6

- | | | | |
|----|----------------------|----|----------------------------|
| 1. | Receiving Module | 3. | AC Line Filter/Relay Board |
| 2. | Decoder/Relay Module | 4. | Power Transformer |

4 Function Settings

4.1 Transmitter Handset

4.1.1 System Channel Settings

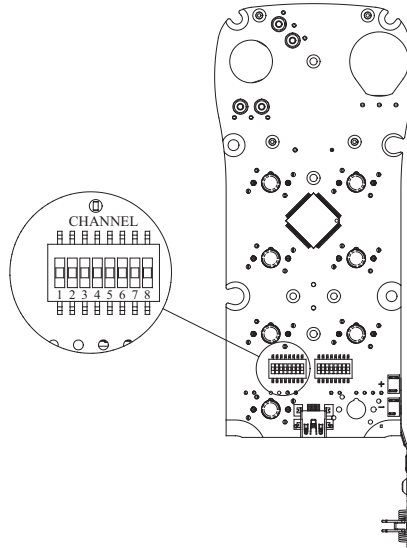

Fig. 7

Set the transmitter channel by adjusting the channel dipswitch located on the backside of the transmitter encoder board (see Fig. 7). Only the first six (6) positions are used for channel programming (see Fig. 8). The system channels table in **Section 5 on page 37** illustrates which dipswitch setting corresponds to which channel. Once the transmitter channel is altered, be sure to change the receiver channel as well. The channel on both the transmitter and the receiver must be identical in order for the system to work. To change the receiver channel, see **Section 4.2.1 on page 28**.

Example:

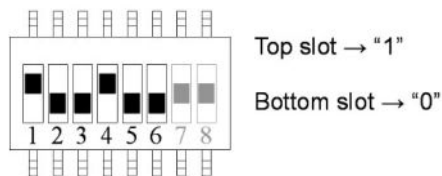

Fig. 8

The above dipswitch setting “1 0 0 1 0 0” corresponds to “channel 36” in the system channels table in **Section 5 on page 37**.

4.1.2 Pushbutton Functions with LED Displays

4.1.2.1 Standard Pushbutton Configuration (Transmitter Toggle)

Set the transmitter toggle (latching output relay) function by adjusting the 8-position function dipswitch located on the backside of the transmitter encoder board (see **Fig. 9**). LED 1 through LED 4 shown inside the shaded box (see below) illustrate which LED on the transmitter will illuminate when the designated pushbutton (PB1-PB4 for 4EX; PB1-PB6 for 6EX) is pressed.

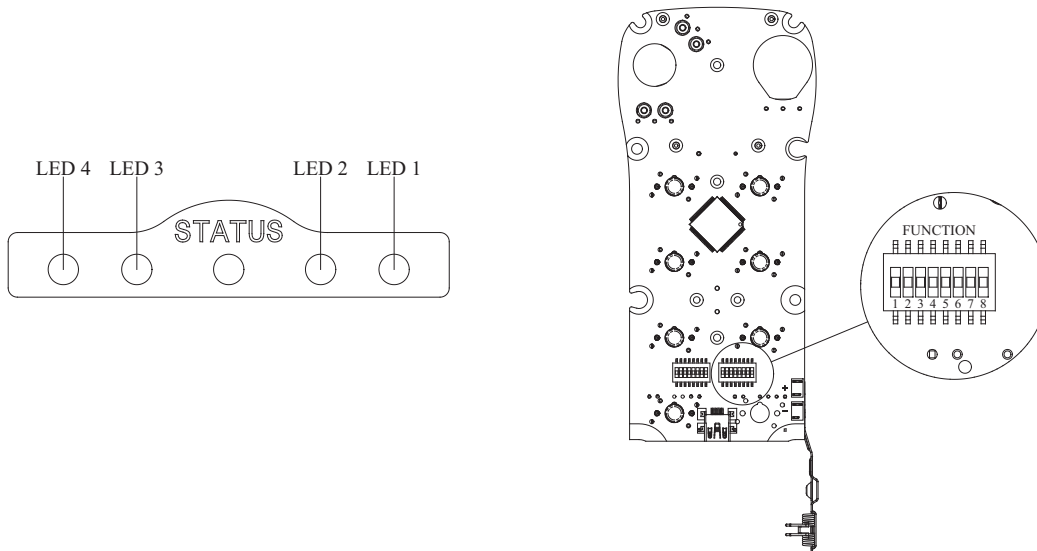

Fig. 9

For 4EX:

	DIP	PB1	PB2	PB3	PB4
1	00000000	Normal	Normal	Normal	Normal
2	00000001	Normal	Normal	Normal	LED 4
3	00000010	Normal	Normal	LED 3	LED 4
4	00000011	Normal	LED 2	LED 3	LED 4
5	00000100	LED 1	LED 2	LED 3	LED 4

PB1...PB4 → Pushbutton number

Normal → Normal momentary contact

LED 1...LED 4 → Transmitter toggled with designated LED Display

For 6EX:

	DIP	PB1	PB2	PB3	PB4	PB5	PB6
1	00000000	Normal	Normal	Normal	Normal	Normal	Normal
2	00000001	Normal	Normal	Normal	LED 4	Normal	Normal
3	00000010	Normal	Normal	LED 3	LED 4	Normal	Normal
4	00000011	Normal	LED 2	LED 3	LED 4	Normal	Normal
5	00000100	LED 1	LED 2	LED 3	LED 4	Normal	Normal
6	00000111	Normal	Normal	Normal	Normal	Normal	LED 2
7	00001000	Normal	Normal	Normal	Normal	LED 1	LED 2

PB1...PB6 → Pushbutton number

Normal → Normal momentary contact

LED 1...LED 4 → Transmitter toggled with designated LED Display

4.1.2.2 A/B Selector Pushbutton Settings

There are four (4) different types of A/B selector sequences available on the Flex system. Choose the one that is most suitable for your application.

Type-A selector sequence: A+B → A → B → A+B...

Type-B selector sequence: Off → A → B → Off → A → B...

Type-C selector sequence: A → B → A+B → A → B → A+B...

Type-D selector sequence: Off → A → B → A+B → Off → A → B → A+B...

For 4EX:

	DIP	PB1	PB2	PB3	PB4
6	00011101	Normal	Normal	A/1&2	Normal
7	00011110	Normal	Normal	B/1&2	Normal
8	00011111	Normal	Normal	C/1&2	Normal
9	00100000	Normal	Normal	D/1&2	Normal
10	00100001	Normal	Normal	Normal	A/3&4
11	00100010	Normal	Normal	Normal	B/3&4
12	00100011	Normal	Normal	Normal	C/3&4
13	00100100	Normal	Normal	Normal	D/3&4
14	00100101	Normal	Normal	A/1&2	A/3&4
15	00100110	Normal	Normal	A/1&2	B/3&4
16	00100111	Normal	Normal	A/1&2	C/3&4
17	00101000	Normal	Normal	A/1&2	D/3&4
18	00101001	Normal	Normal	B/1&2	B/3&4
19	00101010	Normal	Normal	B/1&2	C/3&4
20	00101011	Normal	Normal	B/1&2	D/3&4
21	00101100	Normal	Normal	C/1&2	C/3&4
22	00101101	Normal	Normal	C/1&2	D/3&4
23	00101110	Normal	Normal	D/1&2	D/3&4

PB1...PB4 → Pushbutton number

Normal → Normal momentary contact

A/1&2...D/3&4 → A/B Selector type with designated LED Display (LED 1&2 or LED 3&4)

For 6EX:

	DIP	PB1	PB2	PB3	PB4
8	00011101	Normal	Normal	A/1&2	Normal
9	00011110	Normal	Normal	B/1&2	Normal
10	00011111	Normal	Normal	C/1&2	Normal
11	00100000	Normal	Normal	D/1&2	Normal
12	00100001	Normal	Normal	Normal	A/3&4
13	00100010	Normal	Normal	Normal	B/3&4
14	00100011	Normal	Normal	Normal	C/3&4
15	00100100	Normal	Normal	Normal	D/3&4
16	00100101	Normal	Normal	A/1&2	A/3&4
17	00100110	Normal	Normal	A/1&2	B/3&4
18	00100111	Normal	Normal	A/1&2	C/3&4
19	00101000	Normal	Normal	A/1&2	D/3&4
20	00101001	Normal	Normal	B/1&2	B/3&4
21	00101010	Normal	Normal	B/1&2	C/3&4
22	00101011	Normal	Normal	B/1&2	D/3&4
23	00101100	Normal	Normal	C/1&2	C/3&4
24	00101101	Normal	Normal	C/1&2	D/3&4
25	00101110	Normal	Normal	D/1&2	D/3&4

PB1...PB4 → Pushbutton number

Normal → Normal momentary contact

A/1&2...D/1&2 → A/B Selector type with designated LED Display (LED 1&2)

4.1.3 Channel Change via Pushbuttons

Other than the CHANNEL dipswitch on the encoder board, the transmitter channel can also be changed directly on the pushbuttons. Refer to the instructions below on how to change the transmitter channel via pushbuttons.

1. Press and hold PB1, PB2 and PB3 and rotate the power key to the START position at the same time. A series of green and red blinks will appear on the Status LED, showing the current channel setting. A green blink represents the tens (+10) and a red blink represents the units (+1).

Examples: 2 green blinks followed by 5 red blinks represents channel 25.
6 red blinks represents channel 06.

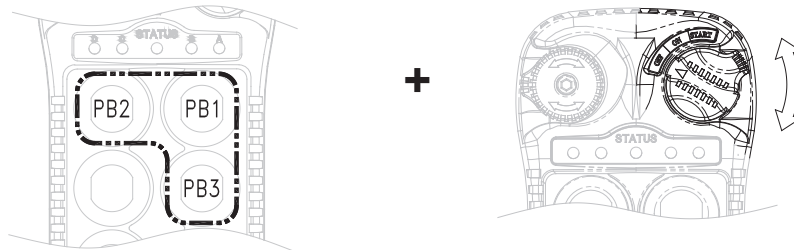

2. Select a new channel by pressing PB1 and PB2 on the transmitter. Press PB1 to increment the units (+1) and PB2 to increment the tens (+10).

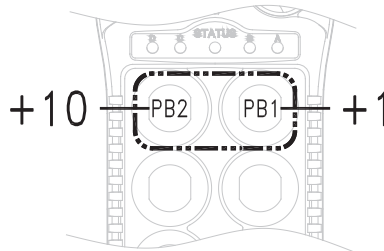

Examples: Pressing PB2 two times and then PB1 four times will give you channel 24.
Pressing PB1 nine times will give you channel 09.

3. When finished, the newly selected channel will appear on the Status LED via a series of green and red blinks again.
4. Exit the channel programming by turning off the transmitter power.
5. Make sure the receiver channel is set identical to the transmitter. **See Section 4.2.1 on page 28** and **Section 4.2.3 on page 32** on how to change the receiver channel.
6. Note that when the CHANNEL dipswitch inside the transmitter is changed, the priority will revert back to the new channel set on the CHANNEL dipswitch.
7. Note that when the channel is set beyond channel 62 via PB1 and PB2 (i.e., channel 63, 68, 88, etc.), the system will recognize it as channel 62.

4.1.4 Optional 4-Digit Security Code

The 4-digit security code is an optional feature that can be programmed into the transmitter to allow operation only to those who know the code. If this feature is desired, set up as follows: Prior to rotating the transmitter power key switch to the START position to begin operation, you must first enter a 4-digit security code in order to proceed. When this 4-digit security code is entered correctly, a green light will appear on the Status LED. See the instructions below on how to program the 4-digit security code.

1. Release the E-Stop, and then press and hold PB1, PB2, PB3 and PB4 simultaneously. Rotate the power key to the START position.



2. A solid orange light will appear on the Status LED indicating that you are in the security code programming mode.
3. For newly purchased systems with the security code function deactivated (default setting), press PB1 four times (1111) to activate the security code function. At this time the Status LED on the transmitter will slowly blink orange, indicating that the 4 digits entered are correct. Then select your own 4-digit security code by pressing PB1, PB2, PB3 or PB4 on the transmitter (four presses randomly). At this time, fast orange blinks are displayed on the Status LED, telling you to reconfirm the 4-digit security code you have just entered. A green light will appear once you have re-entered the same 4-digit security code (programming completed). If any mistake is made during this process, or if a red light illuminates on the Status LED after you have re-entered the security code (incorrect input), or even if you believe you have entered the correct code but the transmitter fails to work properly, then you must reset the transmitter power (by power-cycling the transmitter*) and then repeat steps 1, 2, and 3.

***NOTE:** To power-cycle the transmitter, you must first remove and then reinstall the batteries. Simply turning the power switch off and then on will NOT properly clear the memory. This process must be used for any errors regarding proper transmitter operation (not just for security code settings).

Steps: Press and hold PB1 - PB4 and rotate the power key to the START position → solid orange → press PB1 four times (for new systems) or 4-digit security code → slow orange blinks → enter the new 4-digit security code → fast orange blinks → re-enter the same 4-digit security code → green light.

4. If you wish to cancel the security code function, then repeat steps 1, 2, and 3 and press PB1 four times as your new security code (security code function disabled).
5. If you do not remember the 4-digit security code, you must contact your dealer or distributor for further assistance.

4.1.5 I-CHIP

The I-CHIP functions in a way that is very similar to a SIM card inside a mobile phone, which stores system information such as your telephone number, account number, phone book and other settings. The I-CHIP works exactly the same way, as it stores information such as system serial number/ID code, channel configurations and pushbutton configurations.

When replacing a transmitter handset, remove the I-CHIP from the old transmitter and install it into the new one (*see Fig. 10*). For a complete information transfer, make sure both the Channel and Function dipswitches are set to all "1". If both dipswitches are set to all "1", then the transmitter will operate according to the pushbutton configurations and channel stored inside the I-CHIP. If both the Channel and Function dipswitches are set to values other than all "1", then the transmitter will operate according to the channel and pushbutton configurations set on these two dipswitches rather than the ones stored inside the I-CHIP. Every time the settings on these two dipswitches are changed, the new settings will be stored into the I-CHIP automatically. In this case the previous channel and pushbutton configurations stored inside the I-CHIP will be erased and will be replaced by the new settings.

For safety purposes, the system serial number/ID code stored inside the I-CHIP cannot be changed directly on the transmitter encoder board. Only channels and pushbutton configurations can be changed directly on the encoder board via Channel and Function dipswitches. There are only two ways to change a transmitter serial number/ID code:

1. via the I-CHIP programming port located on the decoder module inside the receiver unit. **See Section 4.2.6 on page 36** on how to program the I-CHIP serial number/ID code via receiver unit.
2. via an external I-CHIP programmer or duplicator unit available from the factory. Please ask your local dealers for assistance if your system requires serial number/ID code adjustments.

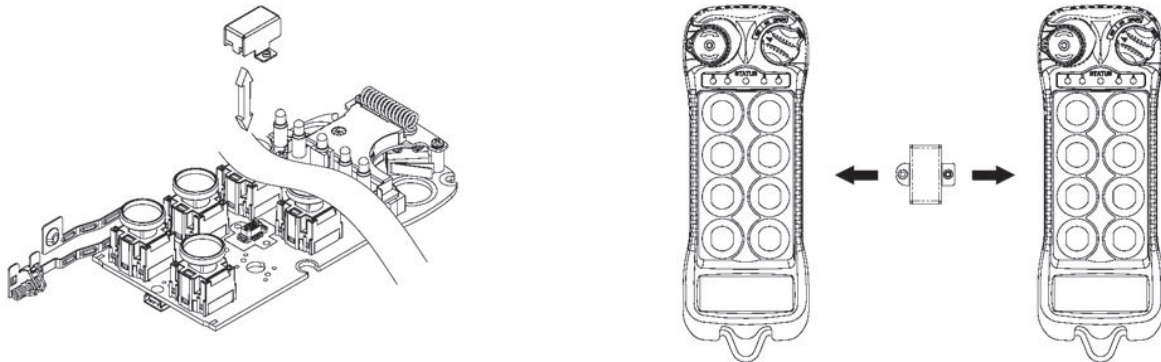

Fig. 10: I-CHIP Installation

4.2 Receiver Unit

4.2.1 System Channel Settings

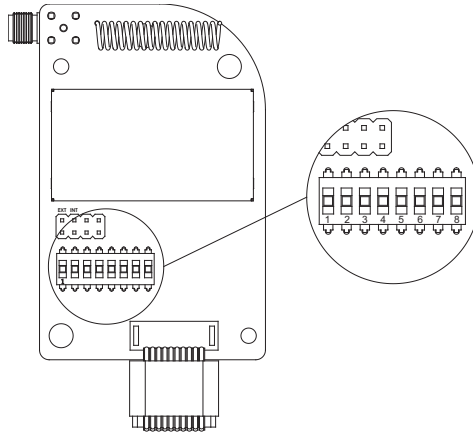

Fig. 11

Even though the Flex system is equipped with an automatic channel scanning receiver, the user can also set the receiver channel manually. **See Section 4.2.3 on page 32** for information on using the automatic channel scanning receiver.

Set the receiver channel by adjusting the channel dipswitch located on the receiver module (**see Fig. 11**). Only the first six (6) positions are used for channel programming (**see Fig. 12**). The system channels table in **Section 5 on page 37** illustrates which dipswitch setting corresponds to which channel. Once the receiver channel is altered, be sure to change the transmitter channel as well. The channel on both the transmitter and the receiver must be identical in order for the system to work. To change the transmitter channel, **see Section 4.1.1 on page 20**.

Example:

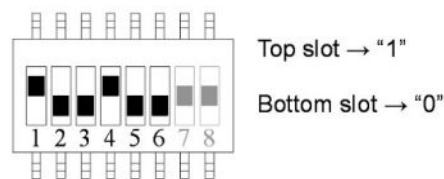

Fig. 12

The above dipswitch setting “1 0 0 1 0 0” corresponds to “channel 36” in the system channels table in **Section 5 on page 37**.

4.2.2 Output Relay Configurations

4.2.2.1 Output Relay Types

1. **3 output relays per motion – shared 2nd speed output relay**

Output relays with Forward 1st speed (F1), Reverse 1st speed (R1) and Forward/Reverse 2nd speed (F/R2). Forward and Reverse 2nd speed (F/R2) share the same output relay.

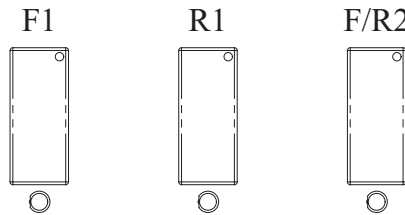

2. **4 output relays per motion – separate 1st and 2nd speed output relays**

Output relays with Forward 1st speed (F1), Reverse 1st speed (R1), Forward 2nd speed (F2) and Reverse 2nd speed (R2). Forward and Reverse 2nd speed with separate output relays.

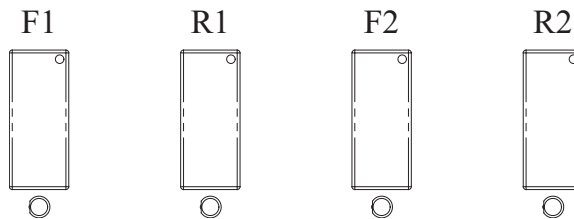

4.2.2.2 Output Relay Actions at 2nd Speed

1. **3 output relay configuration with Closed/Closed contact at 2nd speed***

At 2nd speed, both 1st speed (F1 or R1) and 2nd speed (F/R2) output relays are closed.

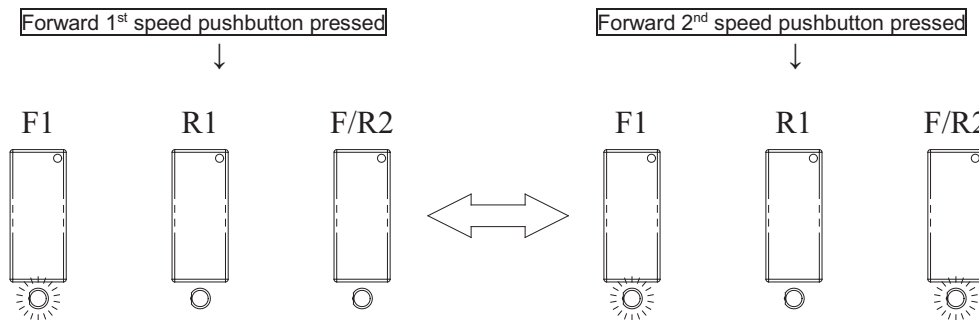

2. 4 output relay configuration with Opened/Closed contact at 2nd speed*

At 2nd speed, only the 2nd speed (F2 or R2) output relay is closed.

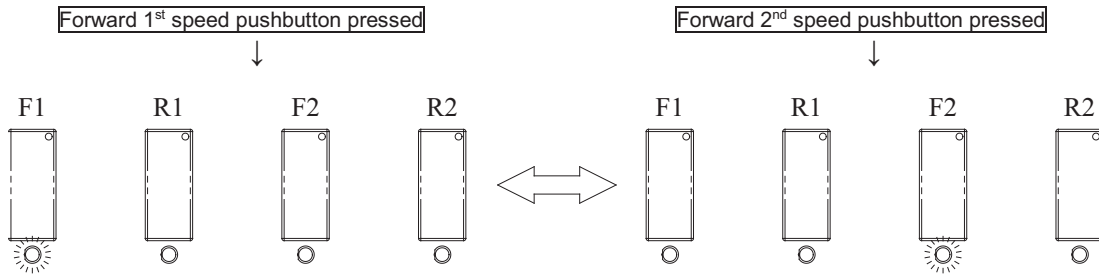

3. 4 output relay configuration with Closed/Closed contact at 2nd speed*

At 2nd speed, both 1st speed (F1 or R1) and 2nd speed (F2 or R2) output relays are closed.

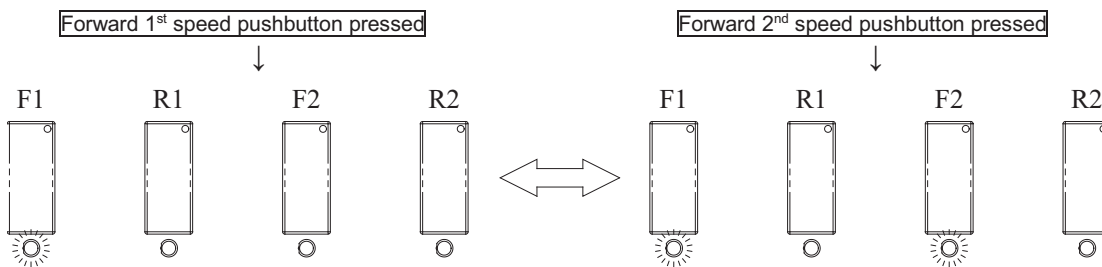

4. 4 output relay configuration with Forward and Fast output relays engaged at 2nd speed*

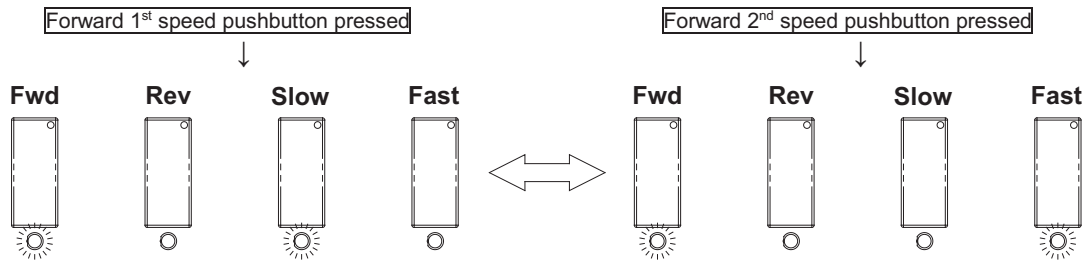

5. 4 output relay configuration with Forward, Slow, and Fast output relays engaged at 2nd speed*

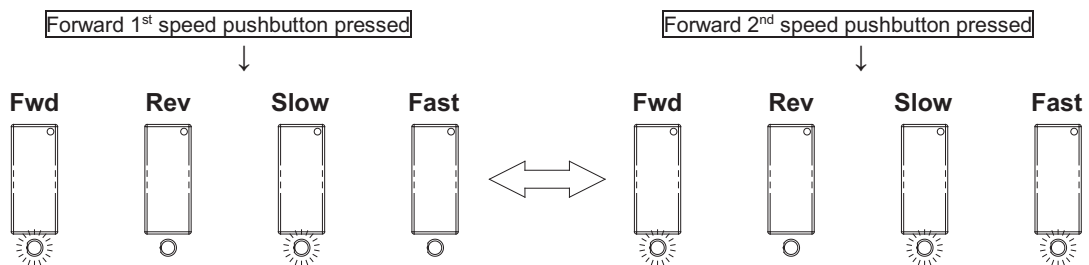

***NOTE:** See Section 4.2.4 on page 33 on how to set this function.

4.2.2.3 ON/OFF Pushbutton Function

The user can set any of the two adjacent pushbuttons on the transmitter to behave like a mechanical ON and OFF rocker switch (see **Section 4.2.4 on page 33** on how to set to this function). When the ON output relay is closed (ON pushbutton pressed), the OFF output relay will open automatically, or vice versa.

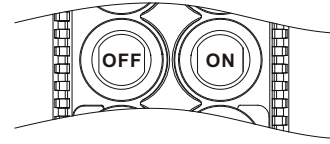

4.2.2.4 START/AUX Function

After initiating the START function, the START position will become an auxiliary function with momentary contact. For an auxiliary application such as a horn or a buzzer, connect it to the FUNC output relay (wire #5) located inside the receiver unit.

4.2.2.5 Brake Function

When the transmitter pushbutton is released from 2nd speed up to 1st speed, both 1st and 2nd speed output relays will open for up to 1 second and then with 1st speed output relay closed thereafter (see **Section 4.2.4 on page 33** on how to set to this function).

4.2.2.6 Momentary Contact

When a pushbutton is released, the output relay corresponding to that pushbutton will open (see **Section 4.2.4 on page 33** on how to set to this function). This type of contact usually applies to external applications such as horns or buzzers.

4.2.2.7 Toggled Contact

When a pushbutton is released, the output relay corresponding to that pushbutton will remain closed (maintain contact) until the next time the user presses the same pushbutton (see **Section 4.2.4 on page 33** on how to set to this function). This type of contact is usually applied to external applications such as lights.

4.2.2.8 3rd Speed Pushbutton Function

This function allows the crane to travel an additional step beyond 2nd speed. For example, if the operator is pressing the UP pushbutton down to 2nd speed, pressing the 3rd speed pushbutton (with UP pushbutton still held at 2nd speed) will toggle between 2nd speed and 3rd speed (see **Section 4.2.4 on page 33** on how to set to this function).

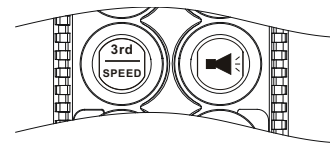

4.2.2.9 Auxiliary STOP Pushbutton Function

The auxiliary STOP function acts as a 2nd emergency stop button. Other than by emergency stop button and transmitter power key switch, the receiver MAIN is also deactivated when this auxiliary STOP pushbutton is pressed (see **Section 4.2.4 on page 33** on how to set to this function).

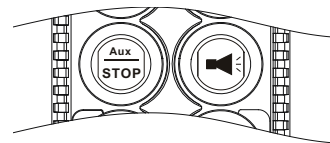

4.2.3 Receiver Auto-Scanning Settings

Receiver Channel Dipswitch

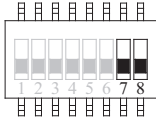
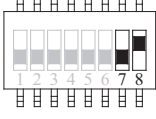
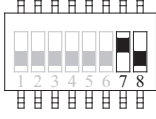
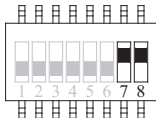
- ↓
- (1)  → Scans all 62 channels (manufacture preset)
For standard operation
- (2)  → Single fixed channel
Auto-scanning function disabled
- (3)  → Scanning 2 channels only (channel X, channel X*+1)
For Pitch & Catch, Tandem, and Random Access operation with 2 receivers
- (4)  → Scanning 3 channels only (channel X*, channel X*+1, channel X*+2)
For Random Access operation with 3 receivers

* Channel X → Channel set on the receiving module

Example: If the first 6 dipswitch positions on the receiving module are set to Ch. 01 (“000000” or “000001”), when set to 2-channel scanning (type 3 above), then the receiver will only scan Ch. 01 and Ch. 02.

4.2.4 Dipswitch Settings

4.2.4.1 Interlocked Functions

Interlocked means the two adjacent pushbuttons cannot be activated simultaneously as they will cancel each other out when pressed. Interlocked settings usually apply to a crane's forward and reverse motions. Each dipswitch on the decoder module corresponds to one (1) motion or two (2) adjacent pushbuttons (*see Fig. 13 and Fig. 14*). Only the first seven (7) dipswitch positions are used (counting from left to right). The 8th dipswitch position (far right) is not used.

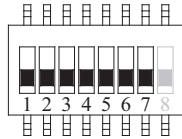

Fig. 13

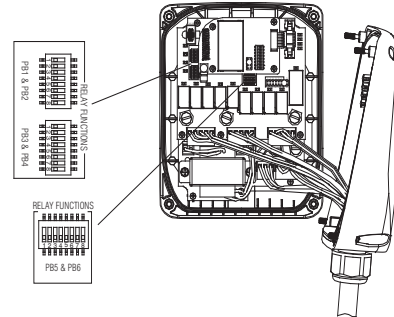

Fig. 14

■ Manufacturer preset

Dip Settings	Function Descriptions	# of Relays Used
0000000	Normal (single speed only, F2 & R2 relays not used)	2
0000001	Closed/Closed Relay Action at 2nd Speed (separate 2nd speed relay)	4
0000010	Closed/Closed Relay Action at 2nd Speed (shared 2nd speed relay)	3
0000011	Opened/Closed Relay Action at 2nd Speed (separate 2nd speed relay)	4
0000100	Forward and Fast output relays engaged at 2nd speed	4
0000101	Forward, Slow, and Fast output relays engaged at 2nd speed	4
0000110	ON (right button) & OFF (left button)	2
0001000	ON & OFF - affected by the E-Stop command. When E-Stop command is initiated, the OFF relay is activated.	2
0001001	ON + START / OFF + START - Prior to pressing the button you must first rotate and hold the power key switch at the START position to activate ON or OFF relays.	2
0001010	FWD/REV toggled (latched)	2
0001011	FWD/REV toggled (latched) and affected by the E-Stop command	2
0100001	Closed/Closed + Brake	4
0100010	Closed/Closed Relay Action + Brake	3
0100011	Opened/Closed Relay Action + Brake	4

4.2.4.2 Non-Interlocked Functions

Contrary to interlocked settings, non-interlocked settings allow the two adjacent pushbuttons to be used simultaneously. Non-interlocked settings are usually applied to a crane's auxiliary functions such as lights, horns, 3rd speed, and auxiliary stop. Each dipswitch on the decoder module corresponds to one (1) motion or two (2) adjacent pushbuttons (left and right pushbuttons).

Function Code	Dip Position Setting #1	Dip Position Setting #2 - #4 (left button) and #5 - #7 (right button)	Function Description
A	1	000	Normal (momentary) contact
B	1	001	Toggled (latching) contact
C	1	010	Acceleration (3rd speed)
D	1	011	Toggled (latching) contact affected by the E-Stop command. When E-Stop command is initiated, all toggled (latching) relays are also deactivated.
E	1	100	Normal + Start function. For added safety, you must first rotate and hold the power key switch at the START position and then press the intended pushbutton at the same time to activate the output relay.
F	1	111	Auxiliary Stop

Example #1: Left button (set to function code A) / right button (set to function code A) → **1 000 000**

Example #2: Left button (set to function code B) / right button (set to function code B) → **1 001 001**

Example #3: Left button (set to function code A) / right button (set to function code C) → **1 000 010**

Example #4: Left button (set to function code C) / right button (set to function code B) → **1 010 001**

NOTE: When set to "Auxiliary Stop", be sure JP3 is inserted (see Section 4.2.5 on page 35).

4.2.5 Jumper Settings

Jumper settings are applied to functions such as main-disconnect time, START function, system information (serial number/ID code) programming, and system testing. Jumpers #1 - #7 are located on the decoder/relay board between the receiving RF module and the output relays (see Fig. 15).

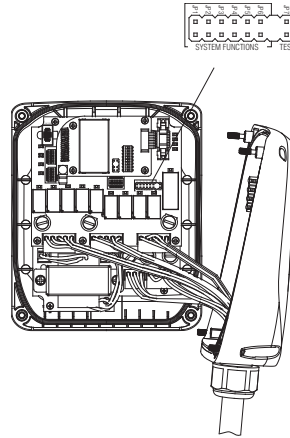

Fig. 15

■ Manufacturer preset

Jumper Settings		Function
JP1 (Blank)	JP2 (Blank)	Receiver MAIN remains closed until the transmitter power is turned off or emergency stop command is initiated
JP1 (Inserted)	JP2 (Blank)	Receiver MAIN opens after 5 minutes of system inactivity
JP1 (Blank)	JP2 (Inserted)	Receiver MAIN opens after 30 minutes of system inactivity
JP1 (Inserted)	JP2 (Inserted)	Receiver MAIN opens after 60 minutes of system inactivity
JP3 (Blank)		Press any pushbutton on the transmitter to activate the receiver MAIN at system startup, after E-Stop reset, and after system inactivity (refer to JP1 & JP2 settings above).
JP3 (Inserted)		Rotate the power key switch to START position to activate the receiver MAIN at system startup, after E-Stop reset, and after system inactivity
JP6 (Blank)		Program system serial number/ID code and channel from decoder module to I-CHIP
JP6 (Inserted)		Program system serial number/ID code and channel from I-CHIP to decoder module
JP7 (Inserted)		For system test only, receiver MAIN is disabled

4.2.6 I-CHIP Programming Port

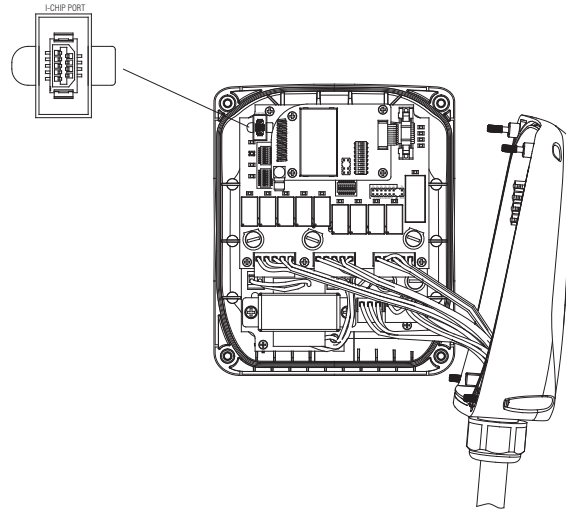

Fig. 16

The I-CHIP programming port located on the decoder module (*see Fig. 16*) inside the receiver is designed for the purpose of transferring system serial number/ID code either from the I-CHIP to the receiver or vice versa. If you wish to transfer system information from the receiver to the I-CHIP, insert the I-CHIP onto the programming port (JP6 jumper not inserted), wait until the Status LED on the decoder module turns a solid green (within 2 seconds), and then take the I-CHIP out of the programming port (programming completed). At this time the I-CHIP should also possess the same serial number/ID code as the receiver.

If the Status LED on the decoder module displays a solid red light after inserting the I-CHIP (programming failed), then you must reinsert the I-CHIP one more time. On the other hand, if you wish to transfer system information from the I-CHIP to the receiver, then you must first insert JP6 jumper prior to inserting the I-CHIP, then wait for the green light to appear on the Status LED. At this time the receiver should also possess the same system information as the I-CHIP. Note that the receiver unit must be powered in order to proceed with the programming.

4.2.7 Fuse Ratings:

FUSE #	110 - 120VAC	220 - 240VAC	380 - 400VAC	410 - 460VAC	24VAC	42 & 48VAC	12 - 24VDC
F1 - F8	5.0A (clear)	5.0A (clear)	5.0A (clear)	5.0A (clear)	5.0A (clear)	5.0A (clear)	5.0A (clear)
F9 - F10	0.5A (blue)	0.5A (blue)	0.5A (blue)	0.5A (blue)	1.0A (red)	1.0A (red)	2.0A (purple)

5 System Channels Table

Channel	Frequency	Dipswitch Setting	Channel	Frequency	Dipswitch Setting
01	433.000MHZ	000000	32*	433.775MHZ	100000
01	433.000MHZ	000001	33*	433.800MHZ	100001
02	433.025MHZ	000010	34*	433.825MHZ	100010
03*	433.050MHZ	000011	35*	433.850MHZ	100011
04*	433.075MHZ	000100	36*	433.875MHZ	100100
05*	433.100MHZ	000101	37*	433.900MHZ	100101
06*	433.125MHZ	000110	38*	433.925MHZ	100110
07*	433.150MHZ	000111	39*	433.950MHZ	100111
08*	433.175MHZ	001000	40*	433.975MHZ	101000
09*	433.200MHZ	001001	41*	434.000MHZ	101001
10*	433.225MHZ	001010	42*	434.025MHZ	101010
11*	433.250MHZ	001011	43*	434.050MHZ	101011
12*	433.275MHZ	001100	44*	434.075MHZ	101100
13*	433.300MHZ	001101	45*	434.100MHZ	101101
14*	433.325MHZ	001110	46*	434.125MHZ	101110
15*	433.350MHZ	001111	47*	434.150MHZ	101111
16*	433.375MHZ	010000	48*	434.175MHZ	110000
17*	433.400MHZ	010001	49*	434.200MHZ	110001
18*	433.425MHZ	010010	50*	434.225MHZ	110010
19*	433.450MHZ	010011	51*	434.250MHZ	110011
20*	433.475MHZ	010100	52*	434.275MHZ	110100
21*	433.500MHZ	010101	53*	434.300MHZ	110101
22*	433.525MHZ	010110	54*	434.325MHZ	110110
23*	433.550MHZ	010111	55*	434.350MHZ	110111
24*	433.575MHZ	011000	56*	434.375MHZ	111000
25*	433.600MHZ	011001	57*	434.400MHZ	111001
26*	433.625MHZ	011010	58*	434.425MHZ	111010
27*	433.650MHZ	011011	59*	434.450MHZ	111011
28*	433.675MHZ	011100	60*	434.475MHZ	111100
29*	433.700MHZ	011101	61*	434.500MHZ	111101
30*	433.725MHZ	011110	62*	434.525MHZ	111110
31*	433.750MHZ	011111	I-CHIP	See Note 2	111111

NOTE 1: Frequencies marked with * are approved for use in Australia.

NOTE 2: When set to all "1" the priority goes to the channel assigned inside the I-CHIP.

6 Receiver Installation

6.1 Output Relay Contact Diagrams

6.1.1 Flex 4EX

Pushbutton 1~2

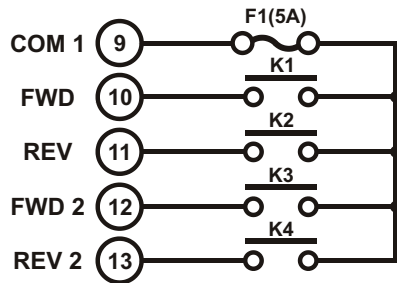

Pushbutton 3~4

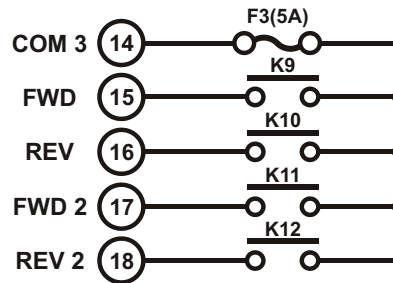

MAIN / Function

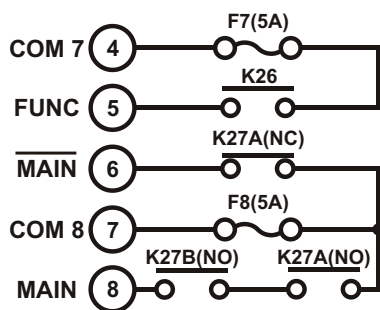

Power

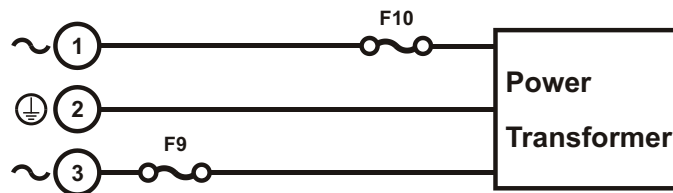

6.1.2 Flex 6EX

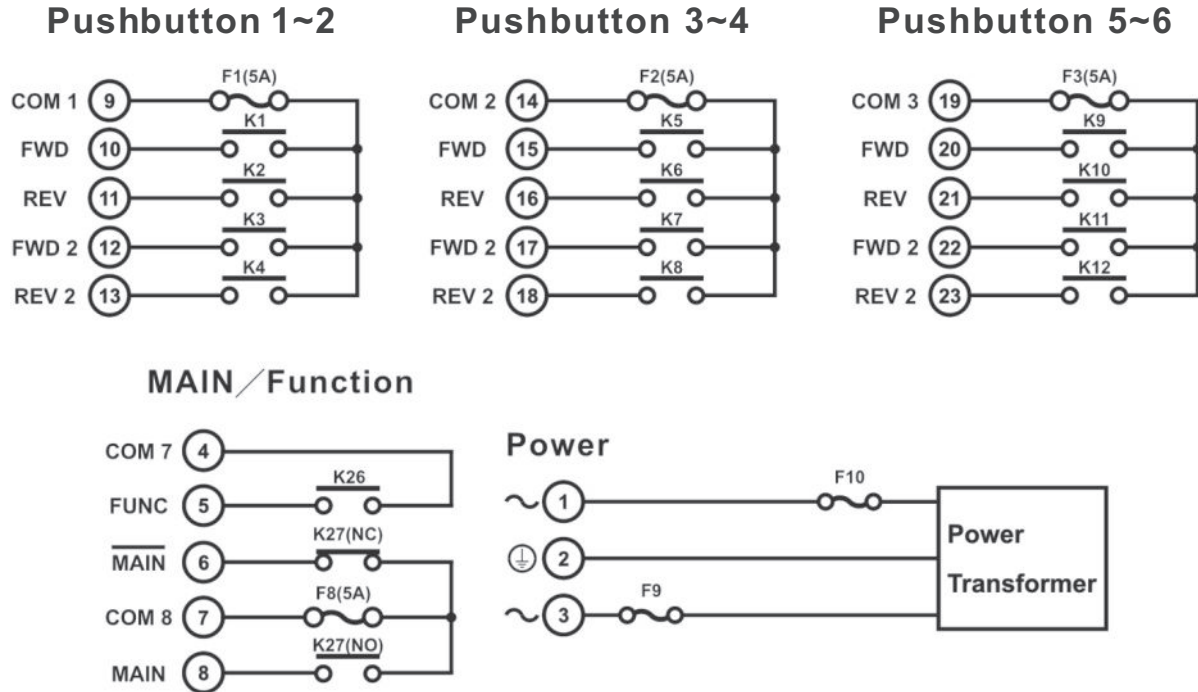

- For 3-relay (shared 2nd speed) and 4-relay (separate 2nd speed) configuration, **see Section 4.2.2.1 on page 29.**
- For 4-relay closed/closed and 4-relay opened/closed configuration, **see Section 4.2.2.2 on page 29.**
- For 12 - 24VDC power supply, wire #1 corresponds to the negative charge (-) and wire #3 corresponds to the positive charge (+). Wire #2 is for GROUND.
- Wire #6 is for “Normal Close” and wire #8 is for “Normal Open” MAIN output.
- Due to the possibility of voltage spikes on the contactors, suppressors are required on contactors being driven by Flex relays.

6.2 Pre-installation Precautions

1. Make sure the transmitter and the receiver have identical serial number/ID codes and channels.
2. Make sure the receiver is not set to the same channel as any other systems in use in the surrounding area.
3. Make sure that the crane or equipment is working properly prior to installation.
4. Make sure the power source to the receiver is set correctly.
5. Switch off the main power source to the crane or equipment prior to installation.

6.3 Step-by-Step Installation

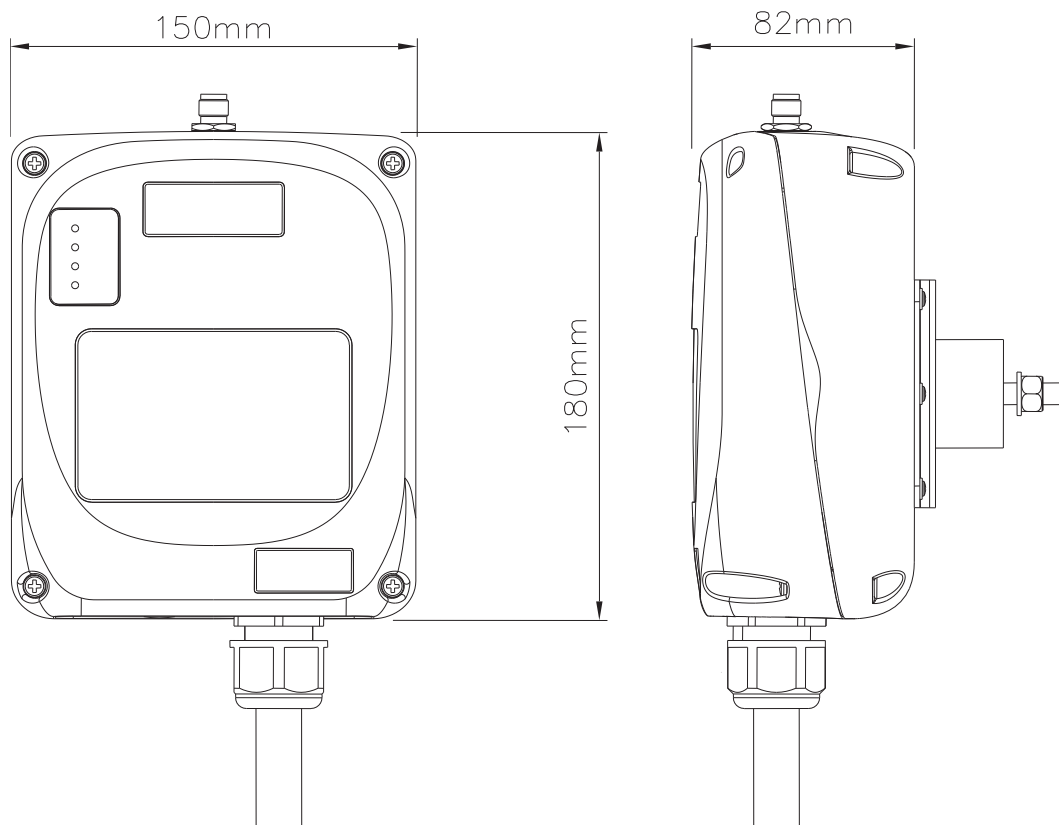

Fig. 17

1. For best reception, the location of the receiver should be visible to the operator at all times.
2. The location selected should not be exposed to high levels of electric noise. Mounting the receiver next to an unshielded variable-frequency drive may cause minor interference. Always locate the receiver as far away from a variable-frequency drive as possible.
3. Ensure the selected location has adequate space to accommodate the receiver. If an external antenna is used, always locate the receiver where the antenna is free from any obstacles from all directions to avoid the possibility of antenna damage (**see Fig. 17**).
4. When installing an external antenna, you must connect the SMA jack located inside the receiver and be sure to set the jumper to “EXT” position.
5. For better reception, make sure the receiver is in an upright position.
6. Drill one hole (8 mm in diameter) on the control panel or location where the receiver is to be installed (**see Fig. 18**).
7. Make sure the bolt is tightened after installation.
8. Install suppressors on all contactors being driven by Flex relays. This is due to the possibility of voltage spikes on the contactors.
9. For system wiring, **see Section 6.1 on page 38**.

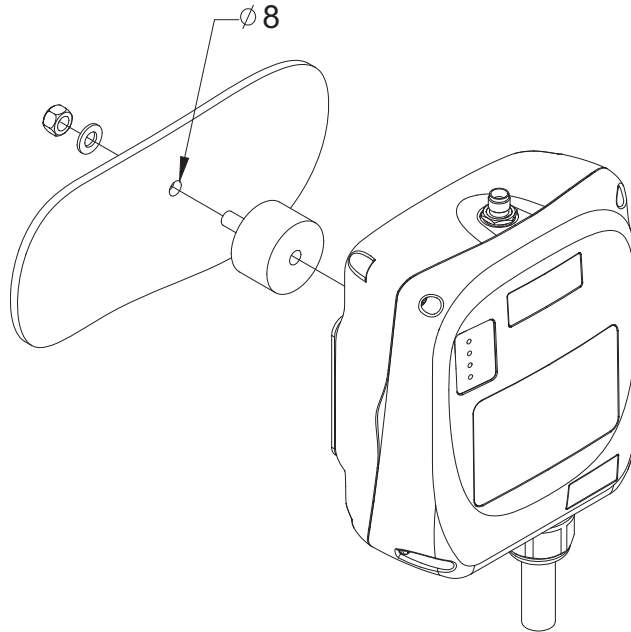

Fig. 18

6.4 System Testing

1. Turn on the power source to the receiver and test the MAIN relay output by pressing the red emergency stop button and observe that it properly opens and closes the mainline disconnect contactor.
2. Test the operation of each function to ensure it corresponds to the transmitter direction labels or the pendant it is replacing.
3. Test the limit switches (if any) to see if they are working properly.
4. If your new remote control is replacing an existing pendant, make sure it is completely disconnected and placed in a safe location to prevent unwanted control commands.

7 Operating Procedure

7.1 Transmitter Operation

7.1.1 General Operating Procedure

1. Reset the red emergency stop button located on the top left side of the transmitter handset by rotating it either clockwise or counterclockwise. The red button will pop up.

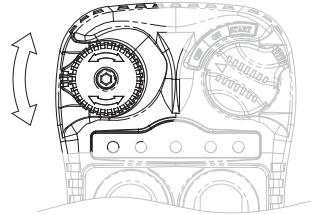

2. Turn on the transmitter power by inserting the black-colored key into the power key slot (located on the top right side of the transmitter handset) and rotate it clockwise to the ON position.

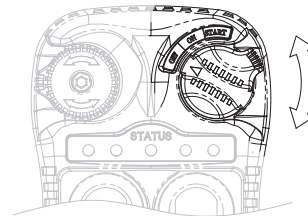
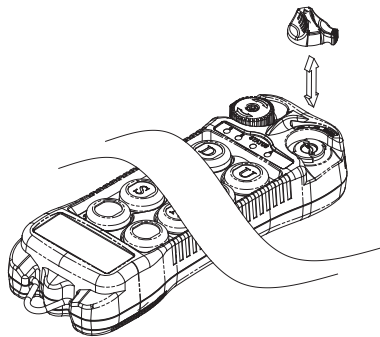

3. After turning on the transmitter power, check the Status LED on the transmitter handset for any sign of system irregularities (**see Section 7.2 on page 45**). If the system is normal, the Status LED will illuminate green for two (2) seconds.
4. If there are no signs of any system irregularities, then rotate the power key further clockwise to the START position for up to two (2) seconds (depending on JP3 setting; **see Section 4.2.5 on page 35**). This will activate all transmitter pushbutton functions, as well as the receiver MAIN. Thereafter, the same START position will become an auxiliary function with momentary contact. Now press any pushbutton on the transmitter handset to operate the crane or equipment. During transmitter inactivity (pushbuttons not pressed), the transmitter will automatically switch to standby mode, with an orange blink on the Status LED at every 4-second interval.

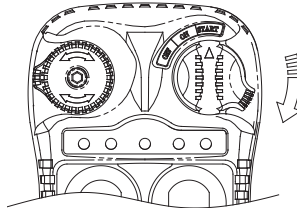

5. In case of an emergency, pressing down the red emergency stop button will immediately disconnect the receiver mainline (Status LED blinks red). To resume operation, rotate the red button either clockwise or counterclockwise until it pops up. Then, rotate the power key to the START position up to 2 seconds to resume operation (depending on JP3 setting; **see Section 4.2.5 on page 35**).
6. After 5 minutes of system inactivity (depending on JP1 & JP2 settings; **see Section 4.2.5 on page 35**), the receiver MAIN will be disconnected temporarily. To resume operation, rotate the power key switch to the START position to reconnect the receiver MAIN (depending on JP3 setting; **see Section 4.2.5 on page 35**). The receiver MAIN will also be disconnected temporarily when the receiver encounters strong radio interference or when the operator is controlling the crane or equipment beyond the transmitting range.
7. To turn off the transmitter power, rotate the power key counterclockwise to the OFF position; it will disconnect the transmitter power and the receiver MAIN altogether. Turn it further counterclockwise to release the key.

7.1.2 A/B Selector Pushbutton Operating Procedure

Pressing the “Select A/B” pushbutton will toggle between output relay A, B, and A+B, respectively. There are 4 different types of Select A/B sequences available; **see Section 4.1.2.2 on page 23** for instructions on how to set select A/B functions.

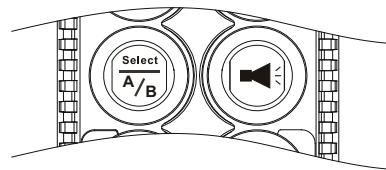
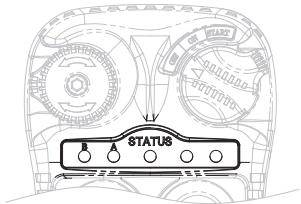

7.1.3 3rd Speed Pushbutton Operating Procedure

When a pushbutton is held at 2nd speed, pressing the 3rd speed pushbutton one time will activate the 3rd speed output relay (toggled). If the operator wants 2nd speed again, press the 3rd speed pushbutton one more time.

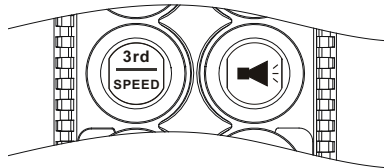

7.1.4 Automatic Channel Scanning Operating Procedure

After changing the transmitter channel (*see Section 4.1.1 on page 20*), turn on the transmitter power, rotate the power key switch to the START position and hold it there for up to 1 minute. Within this 1-minute period, the receiver will search (channel 01 - channel 62) and lock onto the newly selected transmitter channel automatically. Note that in order for the receiver to switch to auto-scanning mode, prior to changing the transmitter channel, you must first deactivate the receiver MAIN by shutting off the transmitter power or press down the emergency stop button. *See Section 4.2.3 on page 32* if you do not want the receiver to auto-scan all 62 channels.

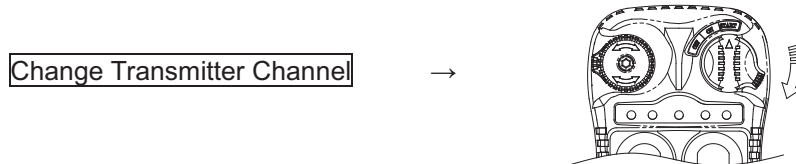

7.1.5 Changing Transmitter Batteries

Change the transmitter batteries by unscrewing the battery cover located on the backside of the transmitter (*see Fig. 19*). During battery installation, make sure that the blue ribbon is centered between the two batteries. After changing the batteries, also make sure that all screws are tightened to avoid water, moisture, dirt, grease, or other liquid penetration.

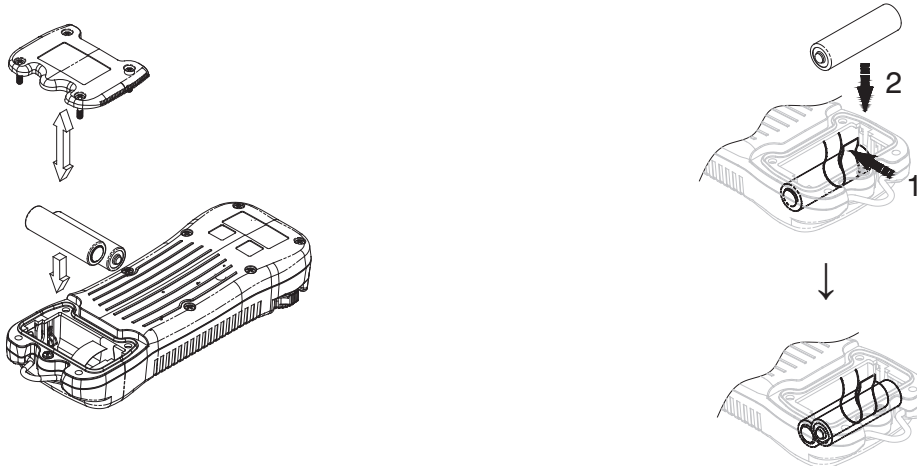

Fig. 19

7.2 Status Light Indicators and Warnings

7.2.1 Transmitter STATUS Light Indication

Type	Display Type	Indication
1	Solid red	Voltage goes below 1.9V at initial power on - transmitter power shuts off.
		Voltage goes below 1.8V during operation - transmitter power shuts off. Turn the power off to disengage the receiver main.
2	1 red blink followed by a 2-second pause	Voltage goes below 1.85V during operation - change batteries immediately.
3	2 red blinks followed by a 2-second pause	The pushbutton is defective after turning on the transmitter power.
4	No light displayed	When a defective pushbutton condition occurs (2 red blinks, type 3 above), find out which pushbutton is defective by pressing all the pushbuttons on the transmitter one at a time. If the pushbutton is in good working order, the LED will not light up when pressed. If the pushbutton is defective, the LED will continue to display 2 red blinks when pressed.
5	3 red blinks followed by a 2-second pause	EEPROM error
6	4 red blinks followed by a 2-second pause	Transmitting error; system cannot lock on to the designated channel.
7	Solid green for up to 2 seconds	Transmitter power on with no faults detected (prior to initiating the START function)
8	Blinking green	Pushbutton pressed, signal transmitted
9	Slow red blinks	Stop command initiated with receiver MAIN deactivated
10	1 orange blink every 4 seconds	Transmitter on standby
11	Alternate red and green blinks	I-CHIP has lost programming. Reprogram the I-CHIP.

7.2.2 Receiver STATUS Light Indication

Type	Display Type	Indication
1	Fast green blinks	Decoding in process
2	Slow green blinks	Decoding on standby
3	Slow red blinks	Stop command initiated with receiver MAIN deactivated
4	2 red blinks	Receiver MAIN jammed or defective
5	Fast red blinks	Incorrect transmitter serial number/ID code
6	Solid red	Receiver under-voltage, LV output relay activated
7	No light displayed	Decoding microprocessor is defective

7.2.3 Receiver SQ Light Indication

Type	Display Type (Red)	Indication
1	On	Transmission received
2	Off	No transmission
3	Blinks intermittently	Other radio interference

7.2.4 Receiver POWER Light Indication

Type	Display Type (Red)	Indication
1	On	Power to receiver
2	Off	No power to receiver

7.2.5 Receiver COM Light Indication

Type	Display Type (Red)	Indication
1	On	Power to relay board
2	Off	No power to relay board

7.3 Troubleshooting Tips

Problems	Possible Reasons	Suggestions
No response when transmitter pushbutton is pressed (improper startup and settings)	Transmitter low battery power	Check the transmitter battery level.
	Emergency stop button activated prior to startup	Prior to turning on the transmitter power switch, make sure the red emergency stop button is elevated.
	Improper startup procedure	Repeat the startup procedure by holding the power key at the START position for up to 2 seconds and then release.
	Incorrect system RF channel	Check and make sure the transmitter handset and the receiver unit both have the same channel.
	Incorrect system serial number/ID code	Check and make sure the transmitter handset and receiver unit both have the same serial number/ID code.
	System out of range	Make sure the startup procedure is initiated within 100 meters (300 feet) from the receiver location.
No response when transmitter pushbutton is pressed (damaged hardware)	Defective transmitting and receiving module	Check the SQ display on the face of the receiver unit. If it does not illuminate when the pushbutton is pressed, then either the transmitting or receiving module is defective. First, replace the transmitting module. If the SQ display is still not lit when the pushbutton is pressed, then replace the receiving module.
	Defective encoder board or decoder module	If still no response, replace the transmitter encoder board. If it is still unresponsive, then the decoder module is defective.
No AC power to the receiver	Incorrect input voltage	Make sure the source voltage is set correctly.
	Blown fuse	Check for any blown fuse.
	Incorrect wiring	Check input voltage connection.
Outputs do not correspond to transmitter	Incorrect output connection	Check the system wiring again. Please refer to the output contact diagram inside this manual or on the receiver cover.

8 System Specifications

Frequency Range:	433 - 434 MHz	
Frequency Deviation:	12.5 KHz	
Number of Channels:	62 channels	
Modulation:	Digital Frequency Modulation based on Manchester Code, 20-bit address, 32-bit CRC Parity Check and Hamming Code.	
Encoder & Decoder:	Microprocessor-controlled	
Transmitting Range:	>100 meters (300 feet)	
Frequency Control:	Synthesized PLL (Phase Lock Loop)	
Receiver Type:	Frequency Auto Scanning	
Receiver Sensitivity:	-116 dBm	
Antenna Impedance:	50 ohms	
Responding Time:	60 milliseconds (average)	
Transmitting Power:	1.0 mW	
Enclosure Type:	NEMA-4X	
Enclosure Rating:	IP66	
Output Contact Rating:	250V @ 8 Amps	
Transmitter Operating Voltage:	3.0VDC	
Receiver Power Consumption:	8.0 VA	
Receiver Supply Voltage:	<u>Voltage Setting</u>	<u>Min - Max</u>
	24VAC	(22 - 26 VAC)
	42VAC	(38 - 46 VAC)
	48VAC	(43 - 53 VAC)
	110VAC	(104 - 126 VAC)
	220VAC	(207 - 253 VAC)
	380VAC	(351 - 429 VAC)
	410VAC	(400 - 480 VAC)
	12/24VDC	(9 - 36 VDC)
Operating Temperature:	-25°C - 75°C / -13°F - 167°F	
Transmitter Dimension:	4EX: 138 mm (L) x 69 mm (W) x 34 mm (H) 6EX: 184 mm (L) x 69 mm (W) x 34 mm (H)	
Receiver Dimension:	180 mm (L) x 150 mm (W) x 82 mm (H)	
Transmitter Weight:	4EX: 192 g / 6.8 oz 6EX: 242 g / 8.5 oz	
Receiver Weight:	2.1 kg/ 4.6 lb (includes output cable)	