

SBN Pendant Pushbutton Station

Instruction Manual



MAGNETEK
MATERIAL HANDLING

Part Number: 126-11173 R2
October 2019

©Copyright 2019 Magnetek Material Handling

Page Intentionally Left Blank

Table of Contents

Service Contact Information	4
Preface and Safety	5
Product Safety Information.....	5
Product Warranty Information	5
DANGER, WARNING, CAUTION, and NOTE Statements.....	6
Product Overview and Features	8
Installation and Wiring	10
Installation Precautions	10
Precautions for Wiring	10
Enclosure disassembly	11
Wiring	11
Enclosure Reassembly	12
Strain Relief Installation when using cable with molded in strain relief cables	13
Strain Relief Installation when using non-strain relief round cable	13
Lens and Legend Replacement	14
Button Hood Replacement	14
Operation	15
General.....	15
Regular Pre-Operation Inspection – Perform at least monthly	15
Safe Crane Operating Procedures.....	16
Appendix A – Cable Armor	17
Type and Dimensions	17
Appendix B – Pendant Switch Schematics	18

Service Contact Information

For questions regarding service or technical information contact:

1-866-MAG-SERV
(1-866-624-7378)

Magnetek Material Handling
N49 W13650 Campbell Drive
Menomonee Falls, WI 53051

Telephone: 800-288-8178

Website: www.magnetek.com

E-mail: mhcustomerservice@magnetek.com

Fax Numbers:

Main: 800-298-3503

Sales: 262-783-3510

Service: 262-783-3508

Magnetek, Inc. has additional satellite locations for Canada and the United States. For more information, please visit <http://www.magnetek.com>.

Preface and Safety

©2016 MAGNETEK

All rights reserved. This notice applies to all copyrighted materials included with this product, including, but not limited to, this manual. This manual is intended for the sole use of the persons to whom it was provided, and any unauthorized distribution of the manual or dispersal of its contents is strictly forbidden. This manual may not be reproduced in whole or in part by any means whatsoever without the expressed written permission of Magnetek.

Product Safety Information

Magnetek, Inc. (Magnetek) offers a broad range of radio remote control products, control products and adjustable frequency drives, industrial braking systems, and power delivery products for material handling applications. This manual has been prepared by Magnetek to provide information and recommendations for the installation, use, operation and service of Magnetek's material handling products and systems (Magnetek Products). Anyone who uses, operates, maintains, services, installs or owns Magnetek Products should know, understand and follow the instructions and safety recommendations in this manual for Magnetek Products.

The recommendations in this manual do not take precedence over any of the following requirements relating to cranes, hoists, lifting devices or other equipment which use or include Magnetek Products:

- Instructions, manuals, and safety warnings of the manufacturers of the equipment where the Magnetek Products are used,
- Plant safety rules and procedures of the employers and the owners of the facilities where the Magnetek Products are being used,
- Regulations issued by the Occupational Health and Safety Administration (OSHA),
- Applicable local, state, provincial, or federal codes, ordinances, standards and requirements, or
- Safety standards and practices for the industries in which Magnetek Products are used.

This manual does not include or address the specific instructions and safety warnings of these manufacturers or any of the other requirements listed above. It is the responsibility of the owners, users and operators of the Magnetek Products to know, understand and follow all of these requirements. It is the responsibility of the employer to make its employees aware of all of the above listed requirements and to make certain that all operators are properly trained.

No one should use Magnetek Products prior to becoming familiar with and being trained in these requirements and the instructions and safety recommendations for this manual.

Product Warranty Information

Magnetek, hereafter referred to as Company, assumes no responsibility for improper programming of a device (such as a drive or radio) by untrained personnel. A device should only be programmed by a trained technician who has read and understands the contents of the relevant manual(s). Improper programming of a device can lead to unexpected, undesirable, or unsafe operation or performance of the device. This may result in damage to equipment or personal injury. Company shall not be liable for economic loss, property damage, or other consequential damages or physical injury sustained by the purchaser or by any third party as a result of such programming. Company neither assumes nor authorizes any other person to assume for Company any other liability in connection with the sale or use of this product.

For information on Magnetek's product warranties by product type, please visit www.magnetek.com.

DANGER, WARNING, CAUTION, and NOTE Statements

Read and understand this manual before installing, operating, or servicing this product. Install the product according to this manual and local codes.

The following conventions indicate safety messages in this manual. Failure to heed these messages could cause fatal injury or damage products and related equipment and systems.



DANGER indicates an imminently hazardous situation which, if not avoided, will result in death or serious injury. This signal word is to be limited to the most extreme situations.



WARNING indicates a potentially hazardous situation which, if not avoided, could result in death or serious injury.



CAUTION indicates a potentially hazardous situation which, if not avoided, could result in minor or moderate injury. It may also be used to alert against unsafe practices.

NOTICE

NOTICE indicates a potential equipment damage message.

NOTE: A NOTE statement is used to notify people of installation, operation, programming, or maintenance information that is important, but not hazard-related.



WARNING

Do not operate an SBN Pendant Pushbutton Station unless you are fully trained and qualified to operate the overhead material handling system of which this SBN is a component. For applications other than overhead cranes and hoists, consult Magnetek at 1-800-288-2178.



WARNING

Read the entire contents of this manual before you install or use the SBN Pendant Pushbutton Station.



CAUTION

Prior to installation, inspection, or repair of pendant stations disconnect power at source, following lockout/tagout procedures as outlined in ANSI Z244.1.



WARNING

If the pendant cable grip is not properly sized to fit the pendant cable, contamination of the pendant housing is possible. Contaminants that enter the switch contacts may result in a potentially unsafe operating condition.

When cutting, stripping, and installing wires, ensure that contaminants do not fall into the enclosure. Contaminants that enter the switch contacts may result in a potentially unsafe operating condition.

Some pendant cable manufacturers add talc to their cable during the manufacturing processes. This talc can migrate from the cable into the housing of the pendant station. As a result, contamination of the switch contacts may occur, resulting in a potentially unsafe operating condition. Use only talc-free cable for the wiring of all pendant stations.

Remove all contaminants from the housing and switch contact areas prior to sealing the enclosure and putting the pendant into service.

NOTE: The maximum ambient temperature rating for the SBN pendant is 40°C (104°F).

Product Overview and Features

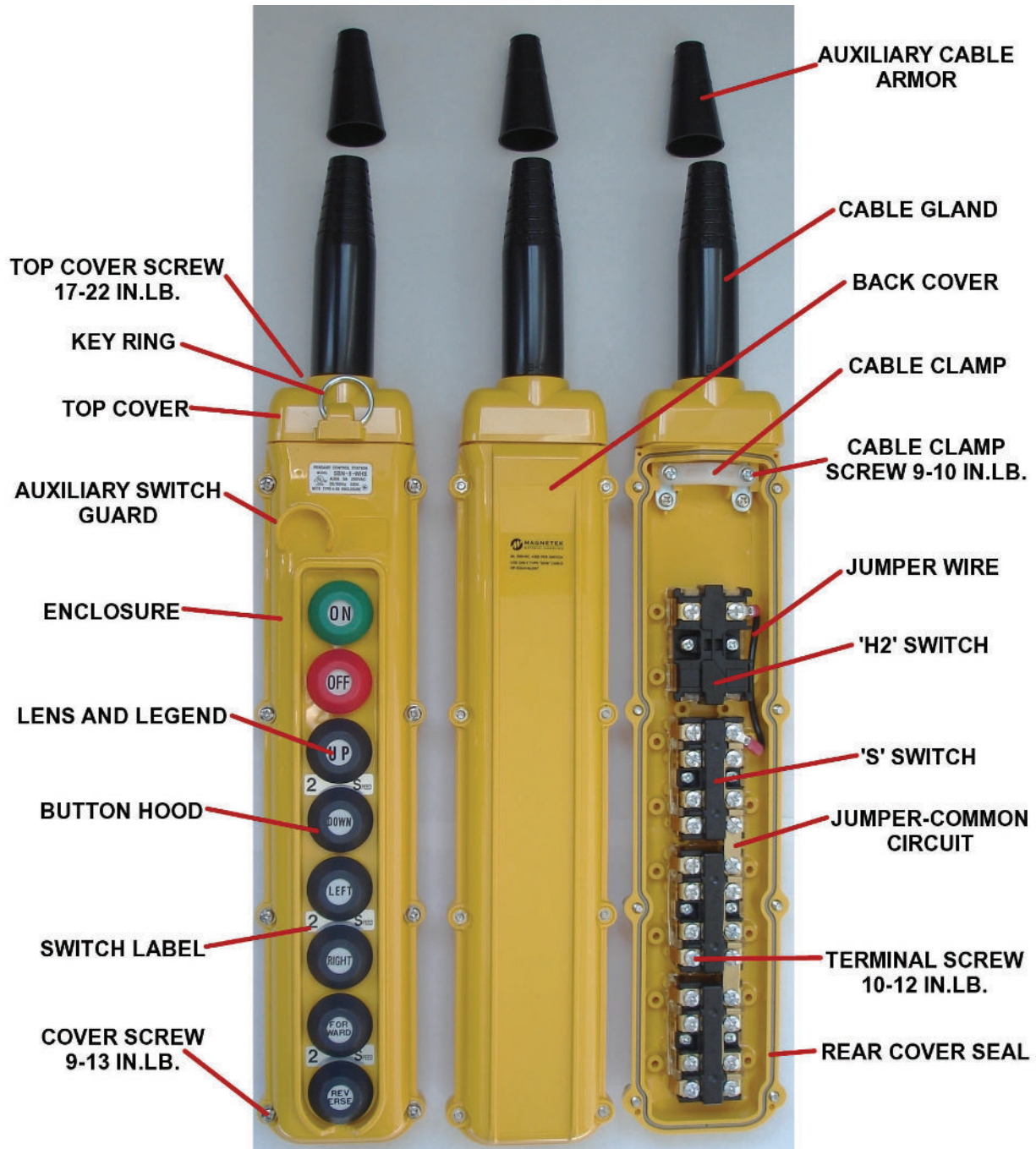

Figure 1: SBN-8-WHS Pendant

The SBN pendant pushbutton station product features:

- Polycarbonate enclosure
- Silicone rubber button hoods
- Captive stainless steel cover screws and molded in cover nuts
- External key ring for strain relief cable attachment
- Internal strain relief clamp
- Pre-wired common circuit
- NEMA 4X rating (see Table 1 for NEMA Rating Designation)
- Visible switch contacts with clear covers

Table 1: NEMA Rating Designation A300 Information – Current Ratings

VAC	Make	Break
120VAC	60A	6A
240VAC	30A	3A

Installation and Wiring

Installation Precautions

- Do not expose the unit to cold blasts of air that might cause condensation (e.g., from an air conditioner).
- Do not expose the unit to cleaning solvents that will penetrate and damage the unit's enclosure.
- Do not use cable that is split or cracked.

Hang the pushbutton station when installing it. Do not place it on a horizontal surface (for example, on a stand or on the floor).

Attach the pushbutton station to the strain relief cable so that no tension is exerted on the pushbutton conductors directly.



HIGH VOLTAGES ARE PRESENT IN THE CONTROL PANEL, JUNCTION BOXES, PENDANT'S ELECTRICAL COMPONENTS, AND THE CONNECTION BETWEEN THESE COMPONENTS.

Before installing, servicing, or inspecting any electrical or mechanical components of this power equipment, power must be disconnected at the source and proper lockout/tagout procedures followed.

DO NOT make or break electrical connections (for example, plugs and receptacles) without first disconnecting power at the source and following proper lockout/tagout procedures.

REFER TO ANSI Z244.1 PERSONNEL PROTECTION – LOCKOUT/TAGOUT OF ENERGY SOURCES.

Only qualified personnel should install components, inspect, and/or service this equipment.

Precautions for Wiring

- If the pendant top cable gland does not fit the connecting cable properly, water or dust may enter the pendant case, get into the switches and cause damage to the switches. Damaged switches may malfunction. Water inside the pendant can conduct electricity and close the switch contacts, causing unintended run commands.
- When cutting or stripping wires, ensure that particles do not fall into that enclosure, as they can jam switch mechanisms or close contacts by conducting across switch gaps.
- Use a UL-listed or CSA-certified, round, crimped-on terminal when connecting to terminals. Do not solder the terminal onto the wire or connect the bare wires directly to the switch terminal screws.

Enclosure disassembly

1. Remove the back cover by loosening the cover screws.
2. Remove the top cover by loosening its two screws. This makes feeding the cable through the top cable entry gland easier.

Wiring

NOTE: Ensure that only type SOW cable is used for the pendant.

NOTE: Use copper conductors only for terminal wiring. The conductor wire sizing should be AWG18 – 16, and the temperature rating should be 60°C (140°F).

Ensure that the cable entry gland opening is at least 1.5mm smaller than the cable diameter that will be fed through it. This difference ensures that the gland will squeeze the cable and provide a seal. The inside diameter of the cable entry gland is marked in millimeters at its top edge. For example, if the top number is 11.5, it means that the inside diameter of the top is 11.5mm. To seal properly, the cable would have to be 13mm diameter or more. If the cable diameter is larger, one or more of the rings may be cut off of the top of the cable gland to get a proper match between the cable and gland opening. In all cases, the gland opening should be smaller than the cable by 1.5mm or more.

For more information on cable armor types and dimensions, see Appendix A – Cable Armor.

Take care that the jacket of the cable that will go through the cable gland is smooth all around. If there are ridges from where the strain relief cables were peeled back, they may prevent a good seal.

The pendant is normally supplied with conical auxiliary cable armor. It sits on top of the cable gland (like a hat) when wiring is complete. This is an additional cover for the gland-cable connection that can provide extra protection against water intrusion. It should be trimmed with scissors (in a single cut) to the proper size. It can be as small as one half (1/2) of the cable diameter that will pass through it because it can be easily stretched. It must be at least 1mm smaller than the cable diameter that will pass through it. Smaller is better within the stated limits as a smaller opening will provide a better seal.

1. Remove or loosen the strain relief cable clamp inside the top of the enclosure.
2. Feed the cable through the auxiliary cable armor, the cable entry gland, and the enclosure until the cable extends along the entire length of the enclosure.
3. Strip back the cable outer jacket to within one inch of the internal strain relief clamp. The jacket must be intact inside the clamp.
4. Screw the top cover to the enclosure making sure that the key ring is facing the front of the pendant.
5. Tighten the internal strain relief cable clamp onto the cable jacket.
6. Cut, strip, and terminate each cable conductor. Keep all pieces of the cable cut during wiring out of the enclosure. Use a UL-listed or CSA-certified, round, crimped-on terminal when connecting to terminals. Do not solder the terminal onto the wire or connect the bare wires directly to the switch terminal screws.
7. Fasten each cable conductor to its respective terminal screw. The tightening torque used should be 10 – 12 lb-in. Do not over-tighten.
8. Check the internal strain relief cable clamp's function. Make sure that there is no tension on any conductors inside the pendant.
9. Mark the opposite ends of the cable's conductors to ensure proper wiring to the control system.

10. The SBN pendant is double insulated. No metal part extends from inside of the enclosure to the outside. Because of this, grounding inside the pendant is not necessary. However, because of the possibility that water could enter the pendant through damaged parts or cable, it is recommended that a ground wire be left extending to the bottom. Insulation should cover the conductor, but the end can be left as cut so that it will contact any water that might build up in the lowest part of the pendant. If there were water inside the pendant and it touched something “live”, the ground wire’s end would also be contacting the water and would be able to conduct current away. Using a ground fault circuit would alert the control system to the abnormal condition.

Enclosure Reassembly

1. Ensure that there are no bare or loose conductor strands and that all conductors are insulated from each other. Make sure that there are no loose pieces of insulation or wire inside the pendant enclosure.
2. Make sure that the seal for the back cover is intact in the groove of the front of the enclosure and not damaged.
3. Put the back cover on while making sure that the wires are tucked inside and do not get between the cover and the enclosure.
4. The top cable gland provides the primary seal between the cable and the pendant. Security of the seal may be augmented by applying a bead of silicone RTV in the area where the cable gland and cable meet.

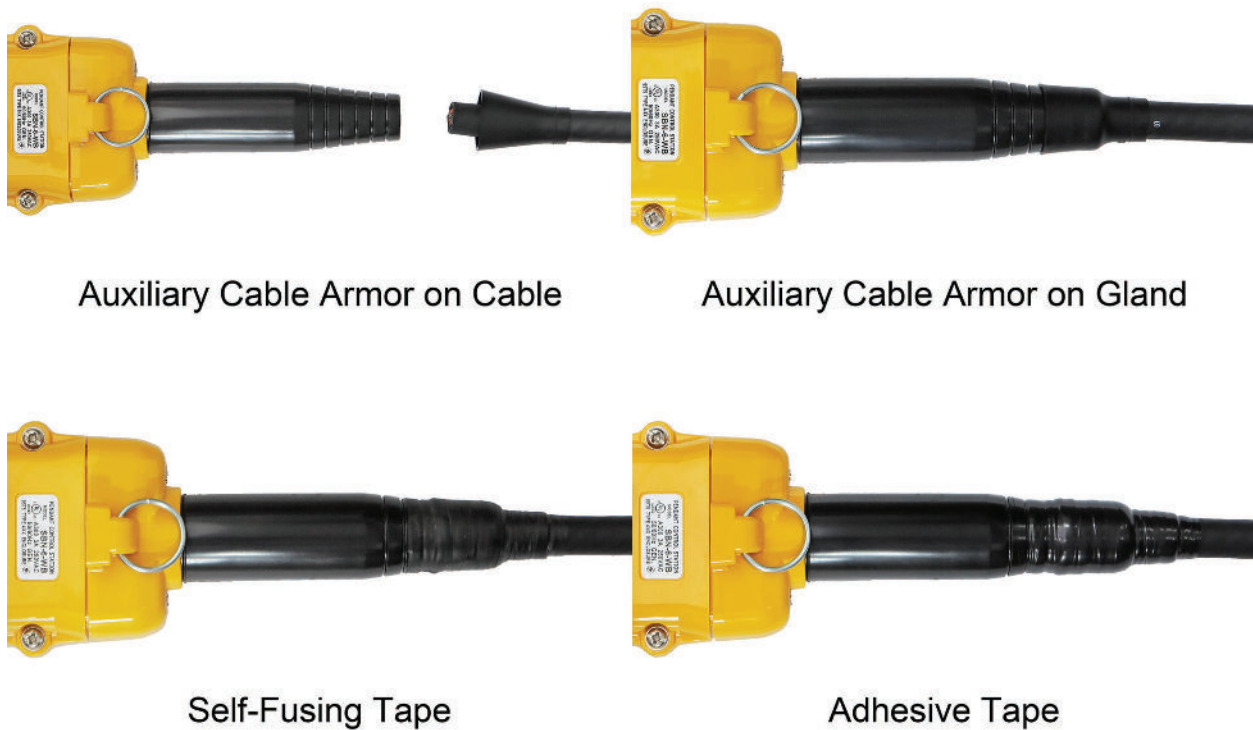

Figure 2: Auxiliary Cable Armor Installation

5. Pull the auxiliary cable armor down to cover the cable and cable gland area. Wrap the auxiliary cable armor with self-fusing electrical tape (non-adhesive) to press the flexible auxiliary cable armor against the cable and cable gland. Overwrap the self-fusing tape with vinyl adhesive electrical tape to protect the area. The purpose of wrapping tape over the auxiliary cable armor is to provide pressure to improve its sealing function. An alternative method can also be followed using adhesive shrink tubing instead of self-fusing tape and vinyl electrical tape.

NOTE: The tightening torque for the front housing screws should be 9 – 13 lb-in, and the tightening torque for the top housing screws should be 17 – 22 lb-in. Do not over-tighten.

Strain Relief Installation when using cable with molded in strain relief cables

Remove the insulation from the steel strain relief cables as shown. Install the strain relief collars with set screws. Thread the strain relief wires through the key ring in the top of the pendants and back through the strain relief collars. Tighten the set screws until the strain relief cables are secure. Trim off the strain relief wires so they are flush with the collars. Tie-wrap the insulated strain relief cables to the main cable to prevent them from peeling away from the main cable.

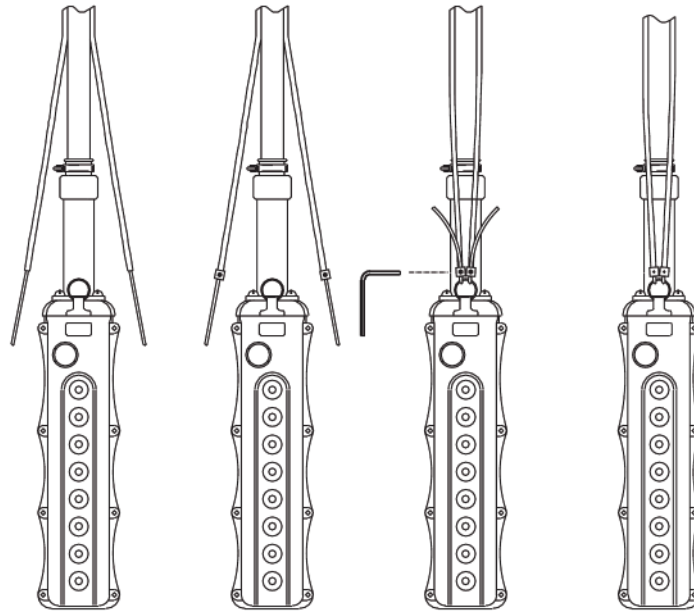

Figure 3: Strain Relief Installation When Using Cable with Molded-In Strain Relief Cables

Strain Relief Installation when using non-strain relief round cable

A loop of cable is made in no-strain relief pendant cable by tie-wrapping the cable in a 12 inch minimum loop; this requires at least 38" of extra cable. Mount a cable grip and strain relief bracket to the opening of the pendant festoon junction box. Use thimbles to protect the strain relief wire from abrasion by the bracket. Fasten the strain relief cables to the bracket, one on each side. Bring the strain relief cables to meet the round pendant cable below the cable loop. Tie-wrap the cables to the round cable below the loop and then tie-wrap them again above the pendant's cable gland. Run the strain relief wires through the key ring in the top of the pendant and secure them with the strain relief collars, tightening the set screws securely.

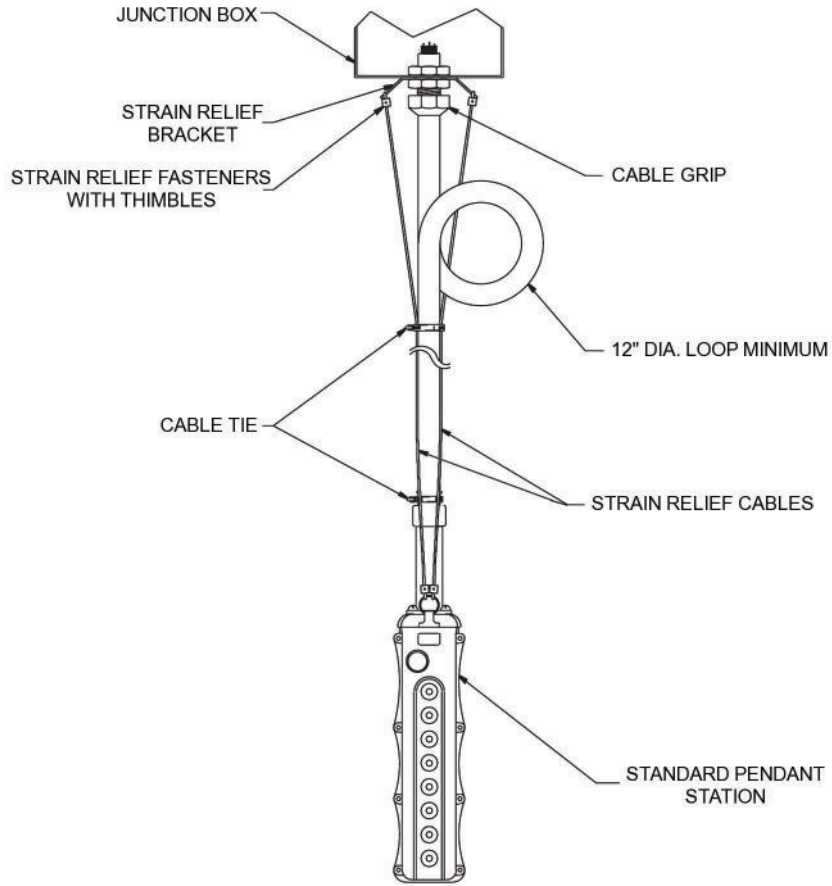

Figure 4: Strain Relief Installation When Using Non-Strain Relief Round Cable

Lens and Legend Replacement

Using a small screwdriver, pry the lens out of the button hood by inserting the blade between the lip of the hood and the lens. Be careful not to damage the button hood. Remove the legend and replace with the selected word or symbol from the legend sheet. Insert the lens over the legend and make sure it is secure.

Button Hood Replacement

Remove the switch under the button hood by unscrewing it. Tear the button hood off with pliers from the outside. Remove the button hood retaining ring from the enclosure with a flat bladed screwdriver, taking care not to damage the enclosure. Insert a new button hood with legend already in place from the outside by pressing it in with both thumbs. Screw the switch back into place.

Operation

General

- Do not place or drop the pendant in water.
- Do not let the pendant slam into objects or people.
- Do not move switches beyond their travel limits.

Regular Pre-Operation Inspection – Perform at least monthly

Before using a pendant station:

- Ensure that the unit's exterior is in good condition with no cracks or sharp edges. Button marking should be legible on all buttons.
- Ensure that the buttons function normally and that the detents clearly indicate how far the button has been depressed. Make sure that buttons return to the OFF position when released. Check that the mechanical interlocks on two button switches are working. Pushing on one button all the way down should prevent its twin from being pressed down.
- Remove any dirt from the outside of the pendant.
- Ensure that the cable is not cut or damaged.
- Ensure that the cable entry point is well sealed.
- Ensure that there are no cracks, cuts or openings in the flexible button hoods.
- Shake the pendant to tell if there are any loose items or water inside. Have a qualified maintenance person investigate if something sounds loose or you are in doubt.
- Ensure that the strain relief cable supports the pendant properly. The strain relief system should be strong enough to support an operator if they stumble while operating the pendant and use it to steady themselves. Under no circumstances should a force applied to the pendant be transferred to the current carrying conductors of the pendant cable.
- The pendant should be hung at a height of approximately 42 inches from the floor, where it will be convenient for the operator to manipulate its switches. If the operator has to bend to grab the pendant, it is likely hung too low.

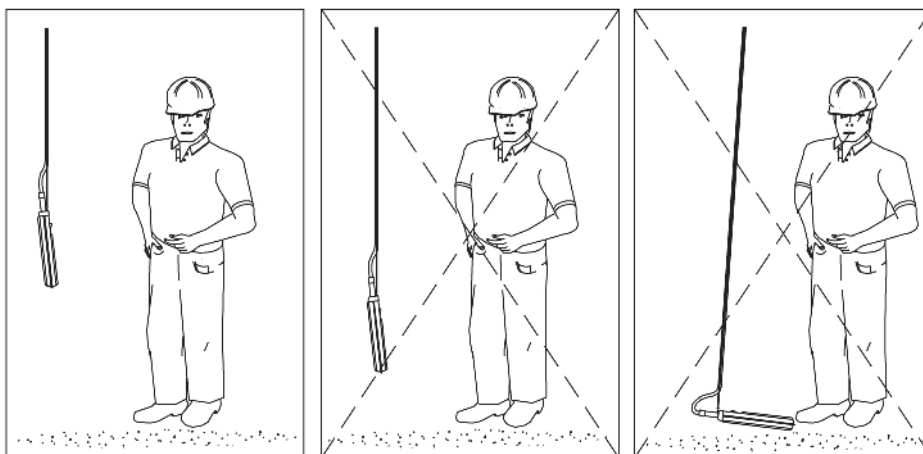

Figure 5: Pendant Height

Safe Crane Operating Procedures

How to operate a crane is beyond the scope of this manual, but a few precautions include:

- Before picking up a load or making a move, ensure that the path of motion for the operator and the load is clear.
- Face the load and stand such that it moves away from you. Do not touch the load when it is being lifted.
- Stay far enough away from a load so that if it drops, it cannot make contact with you or other people.
- Identify and avoid crush zones between the crane, the load, and fixed objects.
- If a problem occurs during operation, stop immediately and contact a qualified maintenance person to investigate the problem.

Appendix A – Cable Armor

NOTE: Please refer to Shinkoh Instruction Manual #SB06151 for more information, if required.

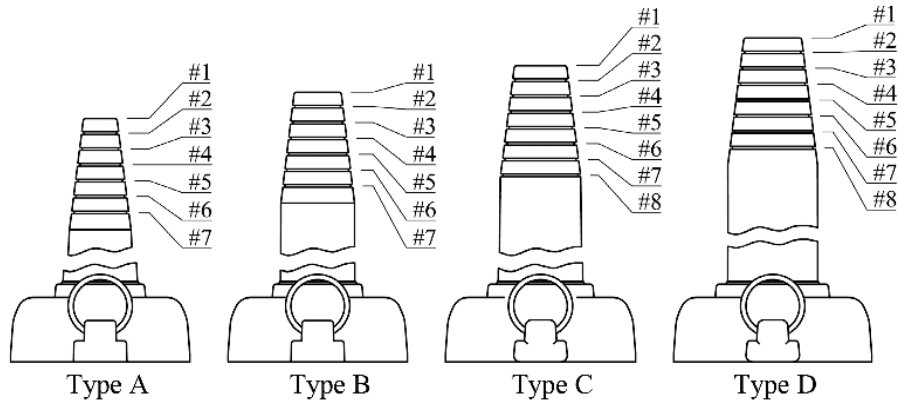

Figure 6: Cable Armor Types and Cutting Points

Type and Dimensions

There are four types of cable armor, which are made for specific SBN models. The models for each type are listed in Table 2, and the # symbol refers to the point where the cable armor should be cut and removed (see Figure 6).

As explained in the Wiring section, cut the armor at a point where its inner diameter is at least 1.5mm smaller than the outer diameter of the connecting cable; this will ensure that the cable armor provides a steadfast seal.

For example, if preparing cable armor for an SBN-2-W, the type of cable armor the unit should come with is Type A. The outer diameter of the cable is 11mm, so the cable armor should be cut at a point where the inner diameter is 9.5mm (11mm – 1.5mm). That would be #3 for Type A cable armor.



CAUTION

Take care to cut the correct cable armor type, and that it is cut at the correct point.

Table 2: Cable Armor Dimensions

Applicable push button station model	Type	Dimensions of the inner diameter (mm)							
		#1	#2	#3	#4	#5	#6	#7	#8
SBN-2-W	A*	6.5	8.0	9.5	11.0	12.5	14.0	15.5	--
SBN-3-W									
SBN-4-W									
SBN-5-W	B*	11.5	13.0	14.5	16.0	17.5	19.0	20.5	--
SBN-6-W									
SBN-8-W (alternate)									
SBN-7-W	C	13.5	15.0	16.5	18.0	19.5	21.0	22.5	24.0
SBN-8-W									
SBN-10-W									
SBIT-8-W									
SBN-12-W	D	15.5	17.0	18.5	20.0	21.5	23.0	24.5	26.0

* Type A and Type B can be exchanged for each other

Appendix B – Pendant Switch Schematics

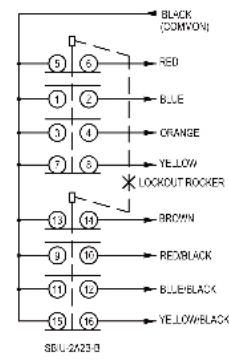
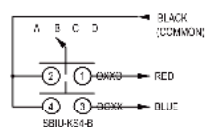
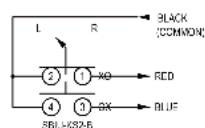
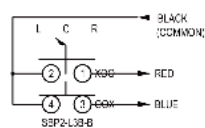
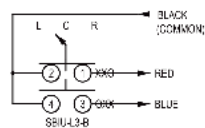
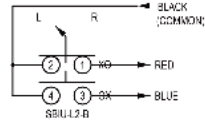
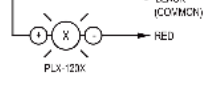
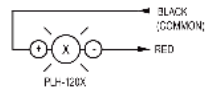
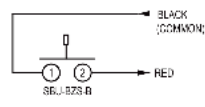
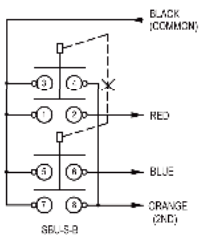
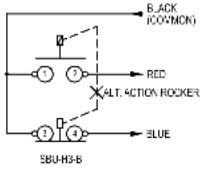
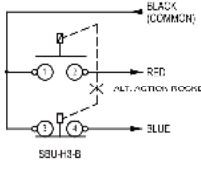
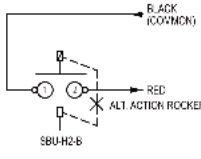
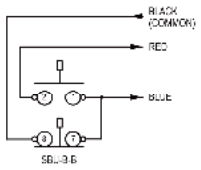
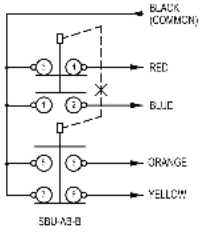
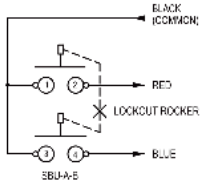
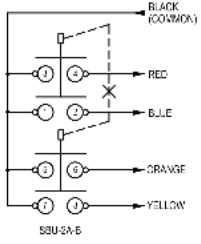
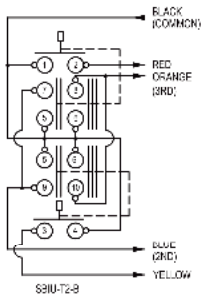
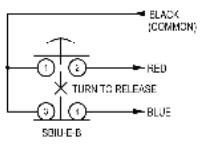
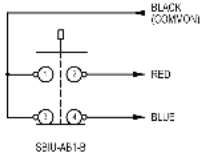
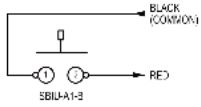



SBN Pendant Pushbutton Station
Instruction Manual
October 2019