

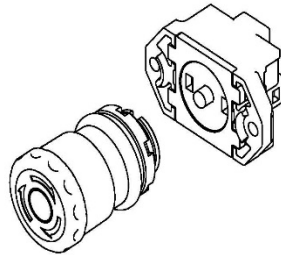

WARNING! Do not install, wire, maintain, or inspect the emergency stop device (E-Stop) while the power supply is turned on. Failure to comply could result in electric shock or fire hazard.

CAUTION! Do not modify the emergency stop device (E-Stop). Failure to comply could result in damage to the E-Stop and will void the warranty. Magnetek is not responsible for any modification of the product made by the user.

Please inspect the delivered product to ensure that it is correct. This instruction sheet should be used for the following Emergency Stop (E-Stop) Button:



Models SBIU-E/SBIU-E-B

Specifications

Specification	E-Stop Model Numbers
	SBIU-E/SBIU-E-B
Enclosures	SBN/SBIT (or equivalent)
Rating	3A 250VAC (AC-15 for electromagnetic switching operation)
Installation Environment	23°F to 104°F (-5°C to 40°C)* *no condensation or freezing
Contact Configuration	<p>1a + 1b</p> <p>Model SBIU-E Model SBIU-E-B</p>

Installation and Wiring

1. Refer to Figure 1 for assembly and removal.

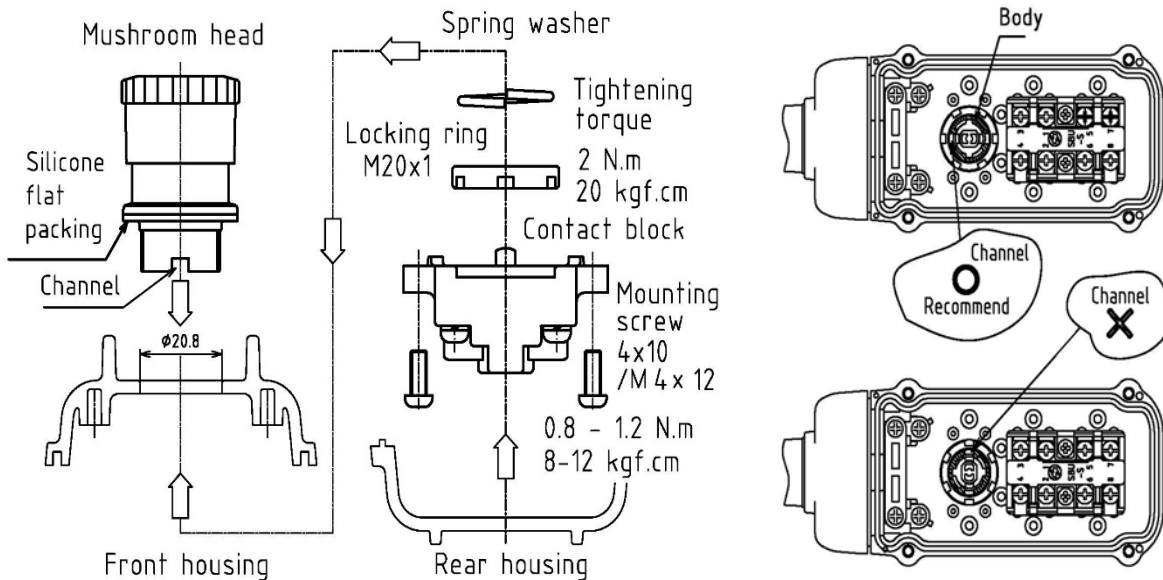

Figure 1: Cross-section and Top View of E-Stop Switch Installation

- Confirm that the gasket of the switch is installed correctly.
- Use properly sized wires to meet voltage and current requirements.
- Tighten the M4 terminal screws to a tightening torque of 1.2 N.m to 1.4 N.m.

WARNING! Improper wires and loose terminals may cause overheating and create a fire hazard during operation. Provide proper protection against electric shocks.

- Use the round crimp terminals.
- There are two channels in the portion of the casing. The channels attach along the length of the enclosure.
- The wrench for the locking ring (Figure 2) is attached to the E-Stop device.

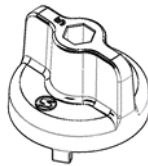

Figure 2: Wrench for the Locking Ring

- Tighten the locking ring with the wrench to a torque of 2.0 N.m.

Operation

Do not expose the E-Stop switch to excessive shocks and vibrations. Otherwise, the switch may become deformed or damaged, causing malfunctions or operation errors.